



## 1064nm Medium Package High Power Polarization Insensitive Isolator (HI Series)

The 1064nm Medium Package High Power Polarization Insensitive Isolator is characterized with low insertion loss, high isolation, high power handling, high return loss, excellent environmental stability and reliability. It is ideal for Fiber Laser, and instrumentation applications.

### Specifications

Parameters	Unit	Grade P	Grade A
Center Wavelength ( $\lambda_c$ )	nm	1064nm or Specify	
Max. PDL	dB	0.1	0.15
Typ. Peak Isolation	dB	35	30
Min. Isolation at 23°C; $\lambda_c$ all polarization states	dB	30	28
Typ. Insertion Loss at 23°C	dB	1.0	1.1
Max. Insertion Loss at 23°C	dB	1.2	1.4
Min. Return Loss (input/output)	dB	50/50	45/45
Max. Optical Power CW	W	3	
Max. Tensile Load	N	5	
Fiber Type		HI 1060 Fiber	
Operating Temperature	°C	0 to +60	
Storage Temperature	°C	-20 to+75	

\*Above specifications are for device without connector.

\*For devices with connectors, IL will be 0.3dB higher, RL will be 5dB lower and optical power will be 2W lower.

### Package Dimensions

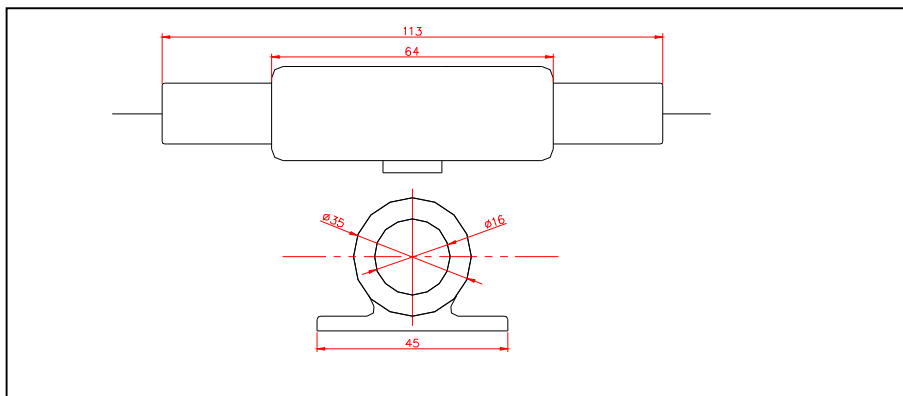

### Ordering Information

MHI-①①-②-③-④-⑤

①①: Wavelength

06 - 1064nm

SS - Specify

②: Grade

P - Premium grade

A - A grade

③: Connector Type

1 - FC/UPC

2 - FC/APC

3 - SC/UPC

4 - SC/APC

N - None

S - Specify

⑤: Fiber Length

1 - 1.0 m

S - Specify

④: Fiber Type

L - 900um loose tube

C - 3mm loose cable

S - Specify

ber