

# Ethernet / Fast Ethernet Bridge Module

## Description

The bridge enables connection of copper and fiber segments to Ethernet and Fast Ethernet whilst at the same time altering the speed. For higher port densities there is a twin bridge available which achieves a higher port density in the distribution equipment by integrating two bridges per card.

In addition to multimode versions, MICROSENS also offers single mode bridges with altered optical parameters, which enable long-range segment links of up to 125 km.

These single mode designs are used in particular for Fiber To The Home (FTTH) projects. The end user can obtain internet services, video on demand and VoIP applications using the familiar 10/100Base-TX copper connection.

An additional operation mode offers the possibility of a symmetric bandwidth limitation. With this service provider can offer their customers individual data rates easily. The provided bandwidth can be configured in small steps to the customer requirements.

The configuration of the features can be done by the network management or the integrated configuration switches.

## Construction

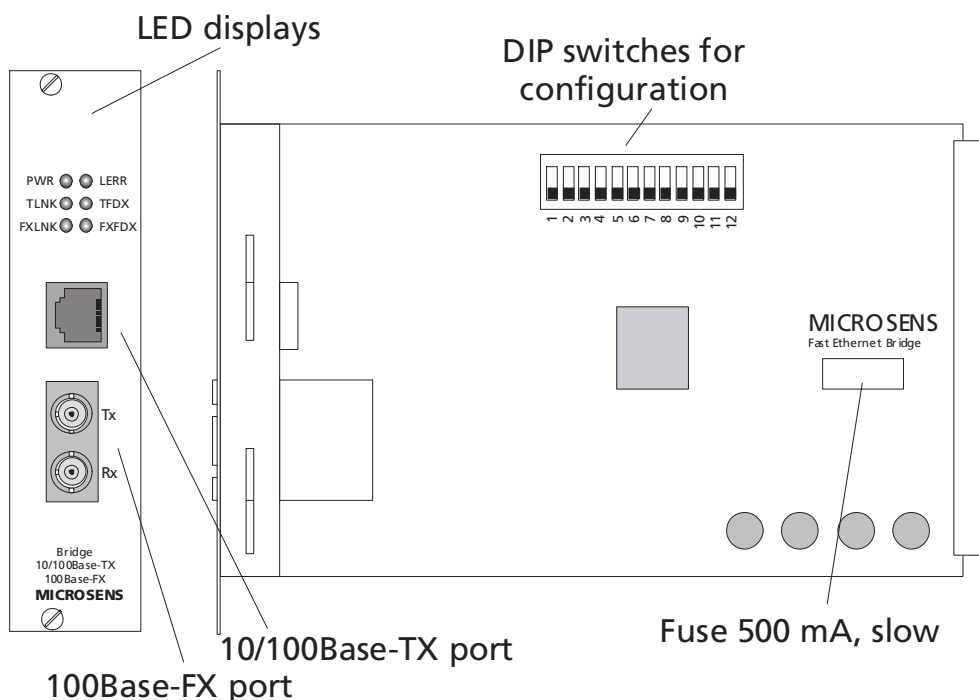

## Technical Specifications

|                        |  |
|------------------------|--|
| <b>Type</b>            | Fast Ethernet Bridge For the coupling of Ethernet and Fast Ethernet segments for the installation in the MICROSENS modular chassis   |
| <b>Fiber type</b>      | Multimode 50 or 62,5/125µm<br>optional single mode 9/125µm duplex  |
| <b>Max. distance</b>   | Full duplex: 2 km (multimode),<br>15..125 km (single mode),<br>Half duplex: 412 m  |
| <b>Cable type</b>      | Shielded Twisted Pair cable, 100 Ohm, Category 5   |
| <b>Data rate</b>       | 10 or 100 Mbps   |
| <b>Max. distance</b>   | 100 m  |
| <b>Configuration</b>   | Manually by DIP switches or by management  |
| <b>LED displays</b>    | <i>PWR</i> Module active<br><i>LNK1</i> Twisted Pair connection correct<br><i>FD1</i> Twisted Pair connection full duplex<br><i>LNK2</i> Fiber connection correct<br><i>FD2</i> Fiber connection full duplex<br><i>ALARM</i> Link Error, no fiber connection |
| <b>Power supply</b>    | 12 V DC / max. 500 mA via backplane  |
| <b>Operating temp.</b> | 0°C to 55°C  |
| <b>Storage temp.</b>   | -20°C to 80°C  |
| <b>Rel. humidity</b>   | 5% to 80% non condensing   |
| <b>Dimensions</b>      | 3 HU x 6 DU (128 x 31 mm)  |
| <b>Management</b>      | optional SNMP-/web based management with management module MS416020-B  |

## Optical Parameter

### Multimode Versions

|                          |  |
|--------------------------|--|
| <i>min. Distance*</i> :  | 2 km (full duplex)                               |
| <i>min. power:</i>       | -19 dBm  |
| <i>min. sensitivity:</i> | -31 dBm  |
| <i>Wavelength</i>        | 1310 nm  |
| <i>Connector:</i>        | SC-duplex (MS416161M2)<br>ST-duplex (MS416160M2) |

### Single mode Versions

|                            |  |
|----------------------------|--|
| <i>min. Distance*</i> :    | 15 km (full duplex)                              |
| <i>min. power:</i>         | -15 dBm  |
| <i>min. sensitivity:</i>   | -31 dBm  |
| <i>max. input power**:</i> | -7 dBm   |
| <i>Wavelength</i>          | 1310 nm  |
| <i>Connector:</i>          | SC-duplex (MS416162M2)<br>ST-duplex (MS416163M2) |

|                            |                        |
|----------------------------|------------------------|
| <i>min. Distance*</i> :    | 40 km (full duplex)    |
| <i>min. power:</i>         | -5 dBm                 |
| <i>min. sensitivity:</i>   | -34 dBm                |
| <i>max. input power**:</i> | 0 dBm                  |
| <i>Wavelength</i>          | 1310 nm                |
| <i>Connector:</i>          | SC-duplex (MS416164M2) |

|                            |                        |
|----------------------------|------------------------|
| <i>min. Distance*</i> :    | 80 km (full duplex)    |
| <i>min. power:</i>         | -5 dBm                 |
| <i>min. sensitivity:</i>   | -34 dBm                |
| <i>max. input power**:</i> | 0 dBm                  |
| <i>Wavelength</i>          | 1550 nm                |
| <i>Connector:</i>          | SC-duplex (MS416165M2) |

|                            |                        |
|----------------------------|------------------------|
| <i>min. Distance*</i> :    | 125 km (full duplex)   |
| <i>min. power:</i>         | 0 dBm                  |
| <i>min. sensitivity:</i>   | -37 dBm                |
| <i>max. input power**:</i> | 0 dBm                  |
| <i>Wavelength</i>          | 1550 nm                |
| <i>Connector:</i>          | SC-duplex (MS416166M2) |

\*The given distances are recommendations, which are valid for the complete lifetime of the laser. The distances are depending on the condition of the transmission line and can vary with the quality of the connected fiber cable, the used connectors and other parameters. Decisive are the optical transmit power and sensitivity. Longer distances are possible without any problems.

\*\* Furthermore the maximum input power of the receiver has to be considered. The values given in this datasheet are minimal (guaranteed) values and can be exceeded by 5-7 dB. If the maximum input levels are exceeded for a long time the device can be damaged.

It is recommended not to mix versions with different distances in one application, e.g. the 15 km version together with the 40 km version. The correct operation can not be guaranteed in this configuration.

## Operation

The module is designed for the mounting into a MICROSENS modular chassis. It can be combined with all other converter modules of the same series.

The power supply is done by a central power supply unit via the backplane of the chassis. Together with the power supply it is possible to insert up to 12 modules into the 3 U chassis. Optional it is possible to insert a second redundant power supply. In this case it is possible to use up to 10 converter modules.

Beside the 3 U chassis there is an additional 1 U chassis (horizontal slots) available. This chassis has an integrated power supply (MS416006), which can be also redundant (MS416007).

Furthermore there are in addition to the 19" racks, desktop chassis for one (MS417001) or two (MS417041) modules available. With the wall bracket (MS417001-WH) it is possible to mount the desktop chassis on the wall.

## Management

The module can be configured and monitored by the central management agent. There are two different modes possible:

**DIP-10 off** Monitoring of the actual configuration and operation states, configuration through the NMS is not possible.

**DIP-10 on** Monitoring with Network management (SNMP- and web based), configuration by web management, terminal or telnet connection.

The SNMP and web based management features of the system are provided by the management master module (MS416020-B). When choosing the management features it is necessary that the chassis (e.g. MS416001M) and the power supply (MS416004M) are also supporting the management.

Visualising - and configuration- example with an SNMP management platform:

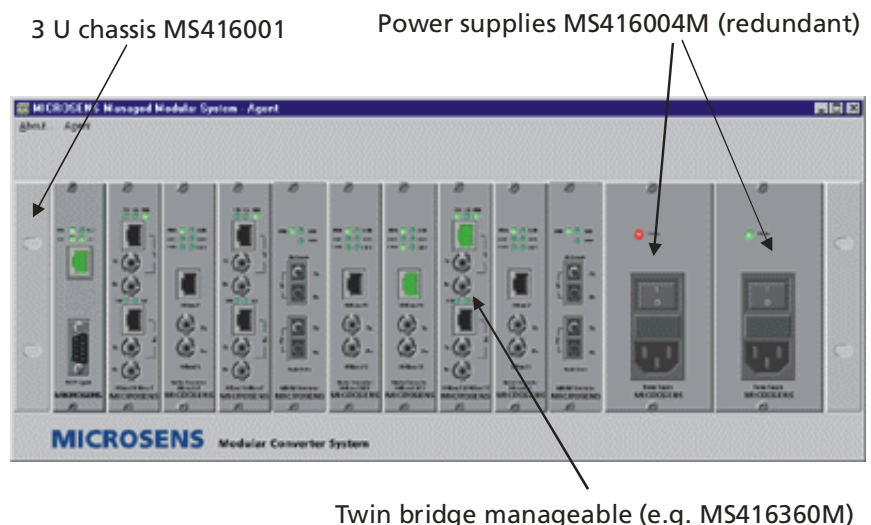

To access the data of the modules via SNMP it is necessary to integrate the structure of the MIB into the existing network management. The MICROSENENS MIB file can be downloaded from the web based management of module. The MIB file is in ASCII format.

The configuration of the network management is protected by a password. The following values are default from the factory.

|          |                    |                |                    |
|----------|--------------------|----------------|--------------------|
|          | Console: Read only | Console: Admin | WEB: Configuration |
| Username | user               | Admin          |                    |
| Password | microsens          | Microsens      | microsens          |

The password for the web based configuration is the same as the administrator password of the console and can be changed together with it.

## Configuration

The configuration of the ports is done manually by either the management (DIP-switch 10: on) or alternative by the DIP-switches (DIP-switch 10: off). As factory default the configuration by management is activated, to allow an immediate access to the configuration.

| DIP-switch | Function (ON/OFF)  |
|------------|--|
| 1          | ALM for fiber port   |
| 2          | Link Through from TP port to fiber port                          |
| 3          | Link Through from fiber port to TP port                          |
| 4          | ON: Full duplex for fiber      OFF: Half duplex for fiber        |
| 5          | ON: Autonegotiation for TP      OFF: 100Mbps, full duplex for TP |
| 6          | Flow Control   |
| 7 – 9      | Bandwidth limitation   |
| 10         | ON: Conf. by Management      OFF: Conf. by DIP-switches          |
| 11         | Reserved   |
| 12         | Reserved   |

The factory default settings are:

| DIP-switch | Function (ON/OFF)                          |
|------------|--|
| 1          | Off  |
| 2          | Off  |
| 3          | Off  |
| 4          | ON: Full duplex for fiber                  |
| 5          | ON: Autonegotiation for TP (10/100Base-TX) |
| 6          | Off  |

|       |                                 |
|-------|---------------------------------|
| 7 – 9 | Off                             |
| 10    | ON: Configuration by Management |
| 11    | Off                             |
| 12    | Off                             |

Additional the bandwidth of the user data can be limited symmetric. By the software management it is possible to limit the bandwidth in steps of 32 kbps or by the DIP-switches in the following steps:

| DIP-switch |   |   | Max. data rate between the ports (each direction) |
|------------|---|---|---|
| 7          | 8 | 9 |   |
| 0          | 0 | 0 | 100 Mbps (100Base-TX), no limitation              |
| 0          | 0 | 1 | 75 Mbps   |
| 0          | 1 | 0 | 50 Mbps   |
| 0          | 1 | 1 | 34 Mbps (E3)                                      |
| 1          | 0 | 0 | 20 Mbps   |
| 1          | 0 | 1 | 10 Mbps (10Base-T)                                |
| 1          | 1 | 0 | 8 Mbps  |
| 1          | 1 | 1 | 2 Mbps (E1)                                       |

0 = Switch OFF, 1 = Switch ON

## Link Trough / ALM

The link status of each segment is forwarded, that means a missing link on the input side also the link signal of the corresponding output side is switched off physically.

**Attention:** If activated by the DIP-switches there is no link signal generated by the bridge in idle state. This is no malfunction!

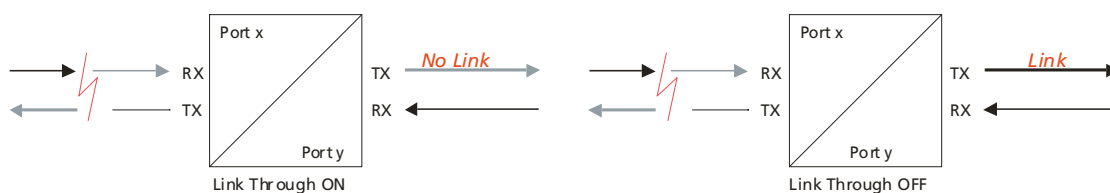

If ALM (Advanced Link Monitoring) is activated the same fiber port is not sending a link signal if he does not receive a link signal (Link Down). This ensures that both directions of the fiber line, TX and RX are having the same link status.



## Safety Notes

**WARNING:** Infrared radiation as used for data transmission within the fiber optic, although invisible to the human eye, can nevertheless cause damage.

*To avoid damage to the eyes:*

- *never look straight into the output of fiber optic components – danger of blinding!*
- *cover all unused optical connections with caps.*
- *commission the transmission link only after completing all connections.*

The active laser components used with this product comply with the provisions of **Laser Class 1**.

## Order Information

| Art.-Nr.   | Description   | Connectors      |                        |
|------------|---|-----------------|------------------------|
| MS416160M2 | Bridge Module, 10/100Base-TX/100Base-FX<br>1310 nm Multimode ST, manageable           | RJ-45<br>2 x ST | 10/100TX<br>100Base-FX |
| MS416161M2 | Bridge Module, 10/100Base-TX/100Base-FX<br>1310 nm Multimode SC, manageable           | RJ-45<br>2 x SC | 10/100TX<br>100Base-FX |
| MS416162M2 | Bridge Module, 10/100Base-TX/100Base-FX<br>1310 nm single mode SC, 15 km, manageable  | RJ-45<br>2 x SC | 10/100TX<br>100Base-FX |
| MS416163M2 | Bridge Module, 10/100Base-TX/100Base-FX<br>1310 nm single mode ST, 15 km, manageable  | RJ-45<br>2 x ST | 10/100TX<br>100Base-FX |
| MS416164M2 | Bridge Module, 10/100Base-TX/100Base-FX<br>1310 nm single mode SC, 40 km, manageable  | RJ-45<br>2 x SC | 10/100TX<br>100Base-FX |
| MS416165M2 | Bridge Module, 10/100Base-TX/100Base-FX<br>1310 nm single mode SC, 80 km, manageable  | RJ-45<br>2 x SC | 10/100TX<br>100Base-FX |
| MS416166M2 | Bridge Module, 10/100Base-TX/100Base-FX<br>1310 nm single mode SC, 125 km, manageable | RJ-45<br>2 x SC | 10/100TX<br>100Base-FX |

MICROSENS reserves the right to make any changes without further notice to any product to improve reliability, function or design. MICROSENS does not assume any liability arising out of the application or use of any product. 2606/He