

Bi-Directional Transceiver TD4x3xx-4xM(STM-4/OC-12)

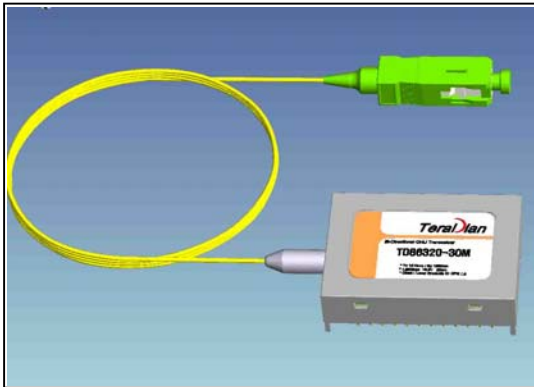

- T1.3 μ m/1.5 μ m or T1.5 μ m/1.3 μ m
Bi-Directional Transceiver with SMF
- Available Data rates of 622Mbps
- Single +3.3V Power Supply
- Diagnostics and control functions
- 2X12 package with pigtailed SC/APC

Family Model

TD46302-4xM	TD46315-4xM	TD46340-4xM
TD47302-4xM	TD47315-4xM	TD47340-4xM

Features

- 1310nm/1550nm WDM for Bi-directional Transceiver with SMF
- 1.31 μ m, 1.55 μ m uncooled InGaAsP SMQW fabry-Perot(FP) LD or distributed feed-back(DFB) LD and APC for constant output Power
- High sensitive InGaAs PIN photodiode used at wavelengths from 1.1 μ m to 1.6 μ m
- Single +3.3V power supply voltage
- LVPECL differential data inputs and outputs
- Diagnostic and control functions through 2-wire interface protocol (I²C)
- Operating temperature ; 0 to +70 $^{\circ}$ C/-40 to +85 $^{\circ}$ C
- 2X12 pins package with pigtailed module with SC/APC connector
- Tested by Teradian's Reliability and Qualification Program

Description

The TD4x3xx series transceivers are designed to operate at 622Mbps continuous mode. The transceivers are designed to used in a single power supply(+3.3V) and an operating temperature range of 0 $^{\circ}$ C to +70 $^{\circ}$ C or -40 $^{\circ}$ C to +85 $^{\circ}$ C. The transceivers are manufactured in 2X12 pin package with Pigtailed SC/PC connector interface and made of metallized housing to obtain excellent EMI shielding. Transmitter incorporates an APC(Automatic Power Control) to maintain the output power and extinction ratio over a case temperature variation. Included in the module function is a transmitter Disable, Failure alarm and input/output power monitoring. Etc.

Applications

Used in telecommunication and data communication systems, from medium to high speed for intra-office, short-haul inter-office and long-haul inter-office applications.

- Intra-office and Inter-office
- Digital Repeater
- Fast Ethernet
- High-speed data links
- Video link

Absolute Maximum Ratings

Parameters	Symbol	Unit	Min.	Max.	Remarks
Ambient Operating Temperature ~ 40km	T_{op}	°C	0 -40	70 85	Indoor use Outdoor use
Storage Temperature	T_{stg}	°C	-40	85	
Supply Voltage	$V_{CC}-V_{EE}$	V	-0.5	6.0	
Lead Soldering Temperature/Time		°C/sec		260/10	
Relative Humidity	RH	%	-	95	

Electrical Characteristics

Parameters	Symbol	Unit	Min.	Typ.	Max.	Remarks
DC Power Supply Voltage	$V_{CC}-V_{EE}$	V	3.1	3.3	3.5	
DC Power Supply Current	$I_{CC,TX}$ $I_{CC,RX}$	mA	35 60		150 80	
Input Data Voltage Swing	$V_{IH}-V_{IL}$	mV	150		800	
Output Data Voltage Swing	$V_{OH}-V_{OL}$	mV	590		800	
Transmit Disable Input Voltage Low High	V_{TDIS}	V			0.8	CMOS/TTL
Signal Detect Output Voltage Low High	V_{SD}	V	- 2.14		1.82 -	LVTTTL

Eye Diagram

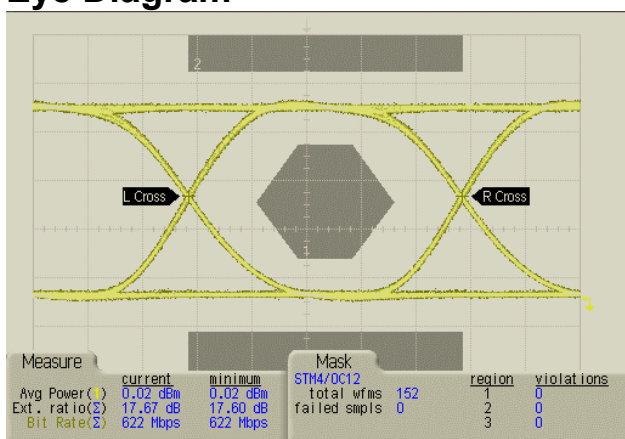

Measured with 622Mbps filter
< Fig. 1 Back-to-back >

Optical Characteristics

(T_{op} = 25°C)

Parameters	Symbol	Condition	Unit	Min.	Typ.	Max.	Remark
Data Bit Rate		PRBS 2 ²³ -1,NRZ	Mbps		622		
Fiber Length 9μm core SMF		10 ⁻¹⁰ BER, 622Mbps	km			40	
TRANSMITTER							
Average Power Output	P _{OUT}	I _f =I _{BIAS} + I _{mod} /2	dBm	-15 -15 -3 -5	-12 -10 -1 -3	-8.0 -8 +2 0	2km 15km 40km(1.3μm) 40km(1.5μm)
Extinction Ratio	ER		dB	9.0			
Center Wavelength	λ _c	CW, @ P _{OUT}	nm	1290 1430 1290 1530	1310 1550 1310 1550	1330 1570 1330 1570	<15km <15km 40km(DFB) 15/40km(DFB)
Spectral Width	Δλ	RMS Width Max. -20dB WD	nm		2.5 2.5	4.0 4.0 1.0 1.0	2km(FP-LD) 15km(FP-LD) 15km(DFB-LD) 40km(DFB-LD)
Side Mode Suppression Ratio	SMSR		dB	30			
Optical Rise/Fall Time	t _r /t _f	10 - 90%	nsec			0.5	
Output Power Monitoring			V	0.1		3.0	
RECEIVER							
Sensitivity (Average Input Power)	P _{IN,MIN}	PRBS 2 ²³ -1, 10 ⁻¹⁰ BER	dBm			-23 -28	2km 15/40km
Receiver Overload	P _{IN,MAX}		dBm	-3.0			
Signal Detect Threshold Decreasing light input Increasing light input	P _D P _A		dBm dBm	-35		-25	
Signal Detect Hysteresis	P _A - P _D		dB	0.5	2.0		
Input power Monitoring			V	0.05		3.0	

Recommended Interface Circuit

The transceiver can operate with LVPECL logic level. The interface circuit is recommended as shown in Figure 2. The power supply filters are required for good EMI performance and should be as close to the transceiver as possible.

- L1=L2=1.0μH
- C1=C4=C5=C8=10μF; C2=C3=C6=C7=0.1μF
- R1=R3=82Ω; R2=R4=130Ω; R5=R6=4.7kΩ ~ 10kΩ

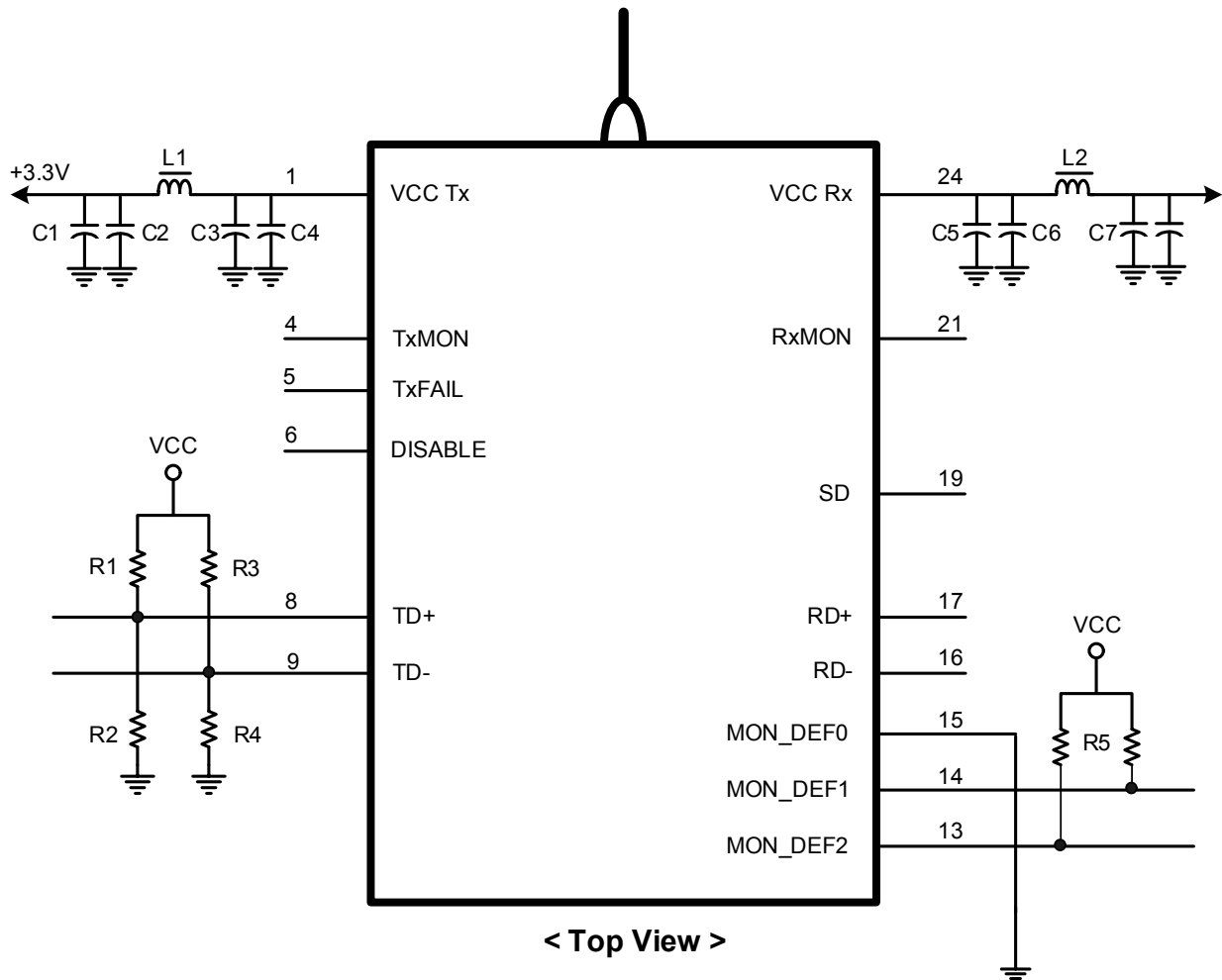

<Fig. 2 Interface of Bi-Directional Module>

Pin Descriptions

Pin (2×12)	Symbol	Function	Logic Family	
Tx	1	Vcc Tx	Transmitter power supply (+3.3V)	
	2	GND Tx	Transmitter Ground	
	3	GND Tx	Transmitter Ground	
	4	TxMON	Output power monitoring	
	5	TxFAIL	Optical output alarm High for normal operation	TTL/CMOS
	6	DISABLE	Optical output shutdown Low for normal operation	TTL/CMOS
	7	GND Tx	Transmitter Ground	
	8	TD+	Positive data input	LVPECL
	9	TD-	Negative data input	LVPECL
	10	GND Tx	Transmitter Ground	
	11	N/C	No Internal Connection	
	12	N/C	No Internal Connection	
Rx	13	N/C	No Connection (Optional) I ² C Serial Communication : SDA	
	14	N/C	No Connection (Optional) I ² C Serial Communication : SCL	
	15	N/C	No Connection (Optional) I ² C Serial Communication : GND	
	16	RD-	Negative data output	LVPECL
	17	RD+	Positive data output	LVPECL
	18	GND Rx	Receiver Ground	
	19	SD	Signal Detect High for normal operation	LVTTL
	20	N/C	No Internal Connection	
	21	RxMON	Input power Monitoring	
	22	GND Rx	Receiver Ground	
	23	GND Rx	Receiver Ground	
	24	VCC Rx	Receiver power supply (+3.3V)	

Outline Diagram(2X12pin)

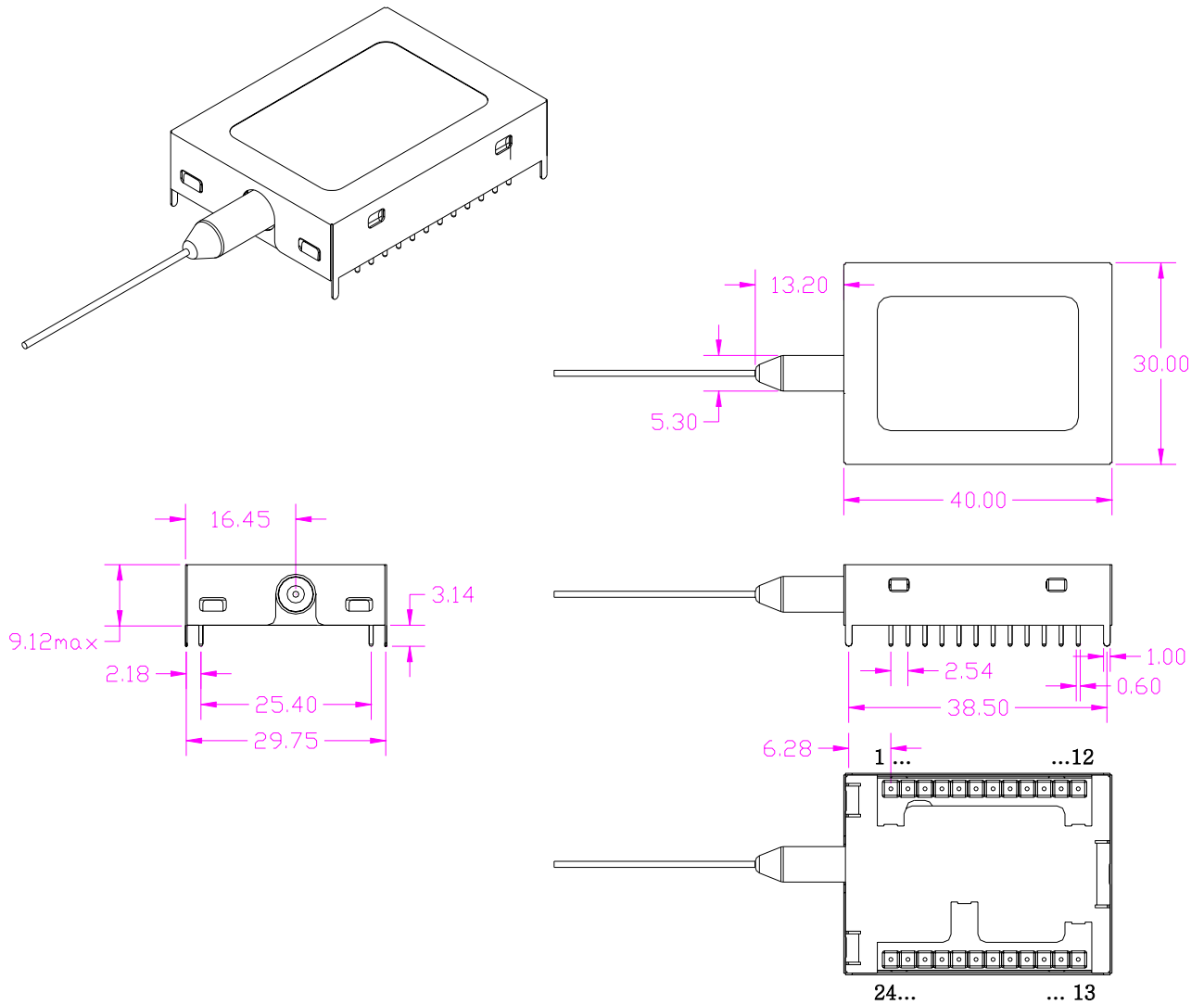

<Fig.3 Package Dimension > [unit : mm]

! Handling Caution

The transceiver can be damaged by overvoltage and current surges. Precautions should be taken for transient power supply.

This device is susceptible to damage as a result of electrostatic discharge(ESD). Take proper precautions during both handling and testing

Laser Eye Safety

These transceivers have laser semiconductor product and are classified as AEL Class I per U.S. FDA/CDRH 21CFR 1040 and class 1 per EN60825-1. These products comply with 21CFR, Chapter 1, Subchapter J(21CFR 1040.10 and 1040.11 laser safety requirements).

Laser Data

Wavelength : 1310nm (Model :), 1550nm(Model :)

Modulation Frequency : 1.25Gbps (duty cycle : 50 percent)

Measured output power(Aperture Size 7mm) : mW

Limit power : mW

! Caution

- All adjustments are made at the factory before shipment to our customers. No maintenance and alteration to device is required.
- Tampering with or modifying the performance of the modules will result in voided product warranty. It may also result in improper operation of the circuitry, and possible overstress of the semiconductor components. Device degradation or product failure may result.
- Use of controls or adjustments or procedures other than those specified herein (ex : Connection of the modules to a non-approved optical source, operating above the recommended absolute maximum conditions, operating in a manner inconsistent with unit design and function) may result in hazardous radiation exposure and may be considered an act of modifying or manufacturing a laser product. The person(s) performing such an act is required by law to recertify the laser product under the provisions of US 21CFR (Subchapter J).
- The use of optical instruments with this product will increase eye hazard.

Notice

On operation, If optical connectors are unterminated, modules can emit invisible laser radiation. Avoided eye exposure to direct or indirect radiation

Ordering Information

Com pany	Func- tion	Data Rate	Wavelength	Supply Voltage	Distance	Pin	Temp. Range	Shielding
T	D	4	6	3	40	4	O	M
Terad- ian	V ;TRV S ;SFF F ;SFP B ;Bi-Di TRV. (Recep- tacle) D ;Bi-Di TRV. (Pig- tailed)	1 ;155Mbps 4 ;622Mbps F ;1.06Gbps 8 ;1.25Gbps 9 ;1.55Gbps S ;2.12Gbps G ;2.5Gbps A ;Asy. Bi-Di 622M/155M E ;Asy. Bi-Di 1.25G/155M O ;Order- made	3 ;1.3 μ m 5 ;1.55 μ m 6 ;Bi-Di T1.3/R1.5 7 ;Bi-Di T1.5/R1.3 8 ;850nm A ;1470nm B ;1490nm C ;1510nm D ;1530nm E ;1550nm F ;1570nm G ;1590nm H ;1610nm M ;1270nm N ;1290nm O ;1310nm P ;1330nm Q ;1350nm R ;1370nm S ;1390nm T ;1410nm U ;1430nm W ;1450nm	3 ;3.3V 5 ;5.0V	SX ;Note1 02 ;2km LX ;5km 10 ;10km 15 ;15km 20 ;20km 30 ;30km 40 ;40km 60 ;60km 80 ;80km A0 ;100km C0 ;120km	1 ;2X5 (10 pin) 2 ;2X10 (20 pin) 4 ;2X12 (24 pin) 9 ;1X9 (9 pin)	I ;Indoor Use (0~70 $^{\circ}$ C) O ;Outdoor Use (-40~85 $^{\circ}$ C)	N ;No Shield M ;Metal or Metal coating

*Note 1 ;

- 220m with 62.5/125 μ m MMF @1.25Gbps
- 500m with 50/125 μ m MMF @1.25Gbps
- 200m with 62.5/125 μ m MMF @2.125Gbps

*Note 2 ; additional order information

- Connector type default is SC/PC and the default length of fiber is 1m
- In case of ordering pigtailed Bi-Di Transceiver, please specify specs. clearly if not default.

More Information

Teradian Inc.

Address 946, Dunsan-dong, Seo-gu, Daejeon, 302-120, Korea
 Tel +82-42-476-4800, 4803(Oversea Sales Team)
 Fax +82-42-476-4805
 Homepage <http://www.teradian.com>
 e-mail sales@teradian.com