

Features

- SMPTE 297-2006 compatible
- Robust error free transmission of signals from 50Mbps to 1.5Gbps.
- Supports video pathological patterns for SD-SDI and HD-SDI
- SFP Package.Hot-pluggable
- Metal enclosure for lower EMI
- +3.3V single power supply.
- Digital diagnostics and control via I²C interface, including:
 - Monitoring of receive optical power, supply voltage and temperature
 - Alarm reporting
 - Module ID polling
- Compliant ROHS and lead free

Applications

- SMPTE 297-2006 compatible optical -to- electrical interfaces

Descriptions

The CRP13F5-11-SDI is a single channel optical receiver module designed to convert optical serial digital signals to electrical serial digital signals as defined in SMPTE 297-2006 . The CRP13F5-11-SDI is specifically designed for robust performance in the presence of SDI pathological patterns for SMPTE 259M, SMPTE 344M and SMPTE 292M serial rates.

Ordering Information

Part Number	Package	Temperature Range
CRP13F5-11-SDI	SFP	0°C to 70°C

Functional Block Diagram

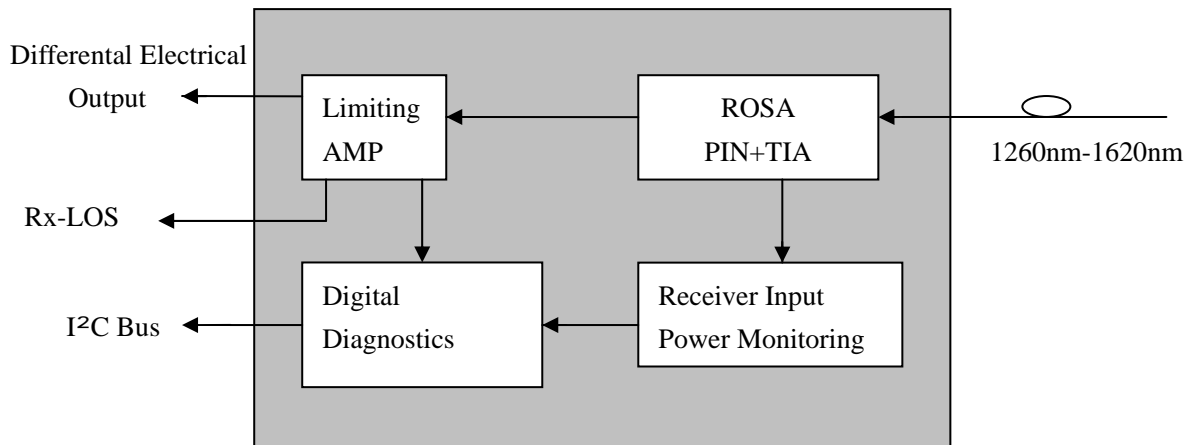

Figure 1: CRP13F5-11-SDI Functional Block Diagram

Pin Description

Pin Out Diagram

20 VEE	1 VEE
19 NC	2 NC
18 NC	3 NC
17 VEE	4 SDA
16 NC	5 SCL
15 VCC	6 Mod-Def
14 VEE	7 NC
13 RD+	8 LOS
12 RD-	9 VEE
11 VEE	10 VEE

Pin Function Definitions

Pin#	Name	Description	Notes
1	VEE	Ground	-
2	NC	No Connection	-
3	NC	No Connection	-
4	SDA	I ² C Data	-
5	SCL	I ² C Clock	-
6	Mod-Def	Module present indicate	Note 1, Grounded in Module
7	NC	No Connection	-
8	LOS	Loss of Signal	Note 2
9	VEE	Ground	-
10	VEE	Ground	-
11	VEE	Ground	-
12	RD-	Inv. Received Data Out	Note 3
13	RD+	Receiver Data out	Note 3
14	VEE	Ground	-
15	VCC	Receiver Power Supply	Note 4, 3.3V ± 5%
16	NC	No Connection	-
17	VEE	Ground	-
18	NC	No Connection	-
19	NC	No Connection	-
20	VEE	Ground	-

Note:

1. Mod-Def should be pulled up with a 4.7K – 10K resistor on the host board. The pull-up voltage shall be VCC. Mod-Def is grounded by the module to indicate that the module is present .
2. LOS (Loss of Signal) is an open collector/drain output, which should be pulled up with a 4.7K – 10K resistor. Pull up voltage between 2.0V and VccT, R+0.3V. When high, this output indicates the received optical power is below the worst-case receiver sensitivity(as defined by the standard in use). Low indicates normal operation. In the low state, the output will be pulled to < 0.8V.
3. VCC is the receiver power supplies. It is defined as 3.3V ± 5% at the SFP connector pin. Maximum supply current is 300mA. Recommended host board power supply filtering is shown below. Inductors with DC resistance of less than 1 should be used in order to

maintain the required voltage at the SFP input pin with 3.3V supply voltage. When the recommended supply filtering network is used, hotplugging of the SFP transceiver module will result in an inrush current of no more than 30 mA greater than the steady state value.

4. RD-/+: These are the differential receiver outputs. They are AC coupled 100 differential lines which should be terminated with 100 (differential) at the user SERDES. The AC coupling is done inside the module and is thus not required on the host board.

Recommended Host Board Supply Filtering

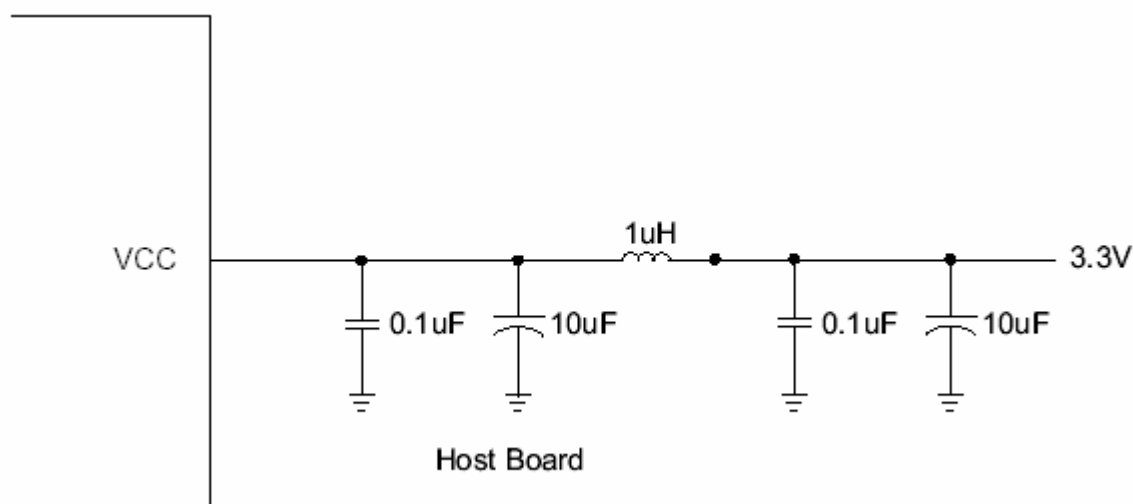

Figure 2: Recommended Host Board Supply Filtering

Optical Connector Requirements

An LC connector with PC/UPC polish is required for each port.

Performance Specifications

Absolute Maximum Ratings

Parameter	Symbol	Min.	Max.	Unit
Storage Temperature	T _{ST}	-40	+85	
Operating case Temperature	T _{case}	-20	+85	
Input Voltage	-	GND	VCC	V
Power Supply Voltage	VCC-VEE	-0.5	+3.6	V

Operating Environment

Parameter	Symbol	Min.	Max.	Unit
Power Supply Voltage	VCC	+3.1	+3.5	V
Operating Temperature	To	0	+70	

Transmitter E-O characteristics

Parameter	Symbol	Min.	Typ.	Max.	Unit	Note
Bit Rate	BR	50	-	1500	Mbps	-
Wavelength	λ	1260	-	1620	nm	-
Saturation	Ps	-7	-	-	dBm	-
LOS Asserted	-	-35	-	-	dBm	-
LOS De-Assert	-	-	-	-22	dBm	-
LOS Hysteresis	-	-	3	-	dB	-
LOS LOW voltage	VLout	-	-	0.8	V	-
LOS HIGH voltage	VHout	2.0	-	-	V	-
Sensitivity for SMPTE 259M 143-360Mbps	-	-	-22	-20	dBm	Pathological PRBS
		-	-24	-22	dBm	
Sensitivity for SMPTE 344M 540Mbps	-	-	-22	-20	dBm	Pathological PRBS
		-	-24	-22	dBm	
Sensitivity for SMPTE 292M 1.485Gbps	-	-	-22	-20	dBm	Pathological PRBS
		-	-24	-22	ps	
Data Outputs Voltage	Vpp	400	800	1000	mV	-
Input Power Monitoring Accuracy		-1		+1	dB	-

Note: The sensitivity specification refers to the input power levels for BER = 1E-12 against PRBS 2²³-1.

EEPROM Section

The optical receiver contains an EEPROM. It provides access to sophisticated identification information that describes the transceiver’s capabilities, standard interfaces, manufacturer, and other information. The serial interface uses the 2-wire serial CMOS EEPROM protocol defined for the ATMEL AT24C01A/02/04 family of components. When the serial protocol is activated, the host generates the serial clock signal (SCL). The positive edge clocks data into those segments of the EEPROM that are not write protected within the SFP transceiver. The negative edge clocks data from the SFP transceiver. The serial data signal (SDA) is bi-directional for serial data transfer. The host uses SDA in conjunction with SCL to mark the start and end of serial protocol activation. The memories are organized as a series of 8-bit data words that can be addressed individually or sequentially.

The Module provides diagnostic information about the present operating conditions. The transceiver generates this diagnostic data by digitization of internal analog signals. Calibration and alarm/warning threshold data is written during device manufacture. Received power monitoring, transmitted power monitoring, bias current monitoring, supply voltage monitoring and temperature monitoring all are implemented. The diagnostic data are raw A/D values and must be converted to real world units using calibration constants stored in EEPROM locations 56 – 95 at wire serial bus address A2h. The digital diagnostic memory map specific data field define as following.

Memory Map:

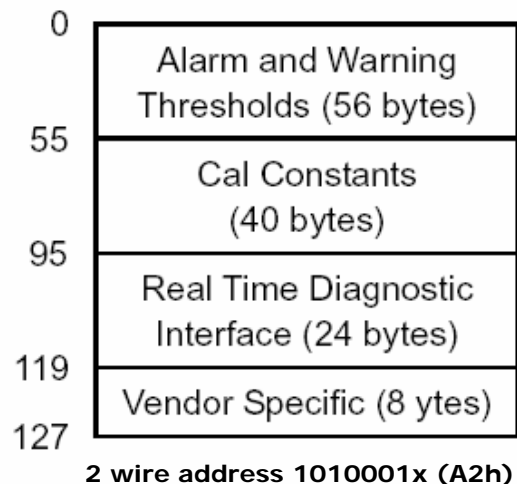
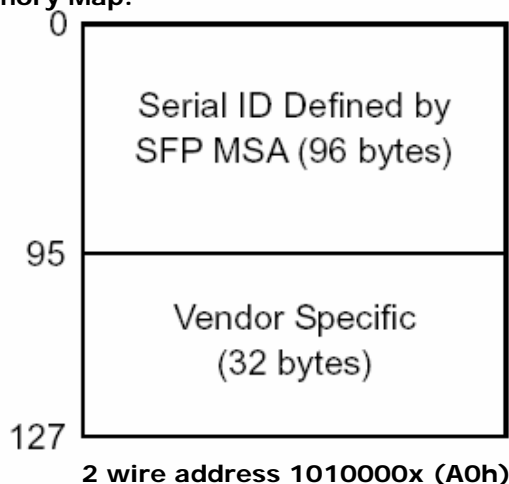

Recommended Circuit

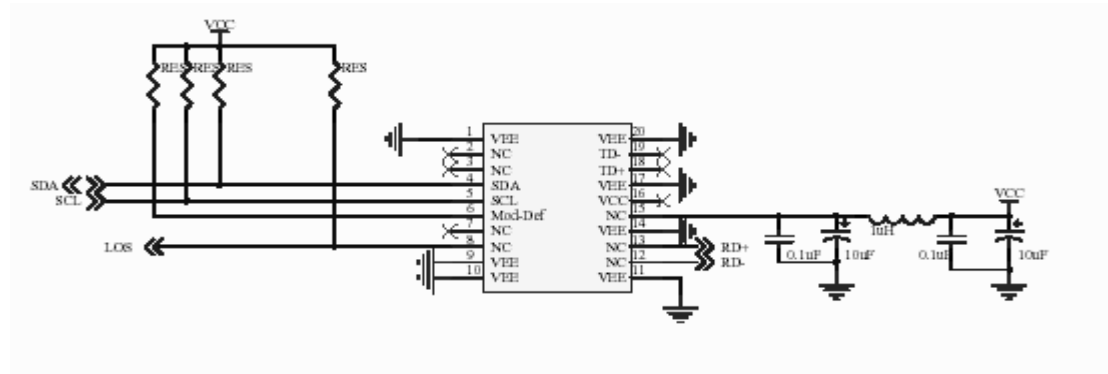

Note: 4.7K ohms < RES < 10K ohms

Figure 3: Recommended Circuit

Package information

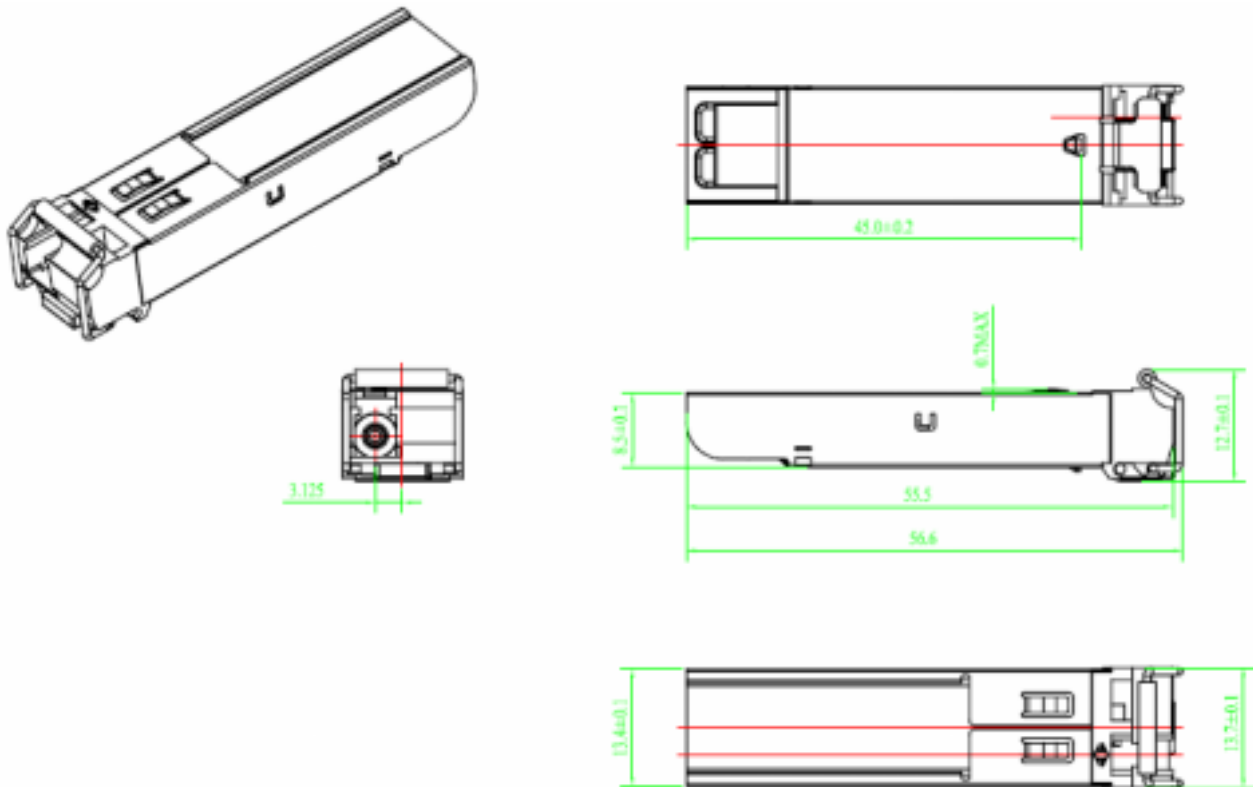

Unit: mm

For More Information

Shenzhen Transwan Optoelectronic Technology co., Ltd

Add: 5F B Building, Zhi Xuan Han YuanLing Industrial Park, Shi Yan, Bao'an, Shenzhen, P.R.C

Tel: +86-755-29003393, 29003397 Fax: +86-755-29003396, 22630311

E-mail: sales@transwan.com.cn website: www.transwan.com.cn