

## Features

- SMPTE 297-2006 compatible
- Robust error free transmission of signals from 50Mbps to 1.5Gbps with up to 30km single-mode fiber
- Maximum distance of 10km under worst-case conditions and 1.5Gbps video pathological signals
- Supports video pathological patterns for SD-SDI and HD-SDI
- SFP Package.Hot-pluggable
- Metal enclosure for lower EMI
- +3.3V single power supply.
- Laser disable pin
- Digital diagnostics and control via I<sup>2</sup>C interface, including:
  - Monitoring laser bias current, average output power, supply voltage and temperature
  - Alarm reporting when transmitter is at fault
  - Module ID polling
- Compliant ROHS and lead free

## Applications

- SMPTE 297-2006 compatible electrical-to-optical interfaces

## Descriptions

The CTP13F5-11-SDI is a single channel optical transmitter module designed to transmit optical serial digital signals as defined in SMPTE 297-2006. The CTP13F5-11-SDI is specifically designed for robust performance in the presence of SDI pathological patterns for SMPTE 259M, SMPTE 344M and SMPTE 292M serial rates.

## Ordering Information

Part Number	Package	Temperature Range
CTP13F5-11-SDI	SFP	0°C to 70°C

**Functional Block Diagram**

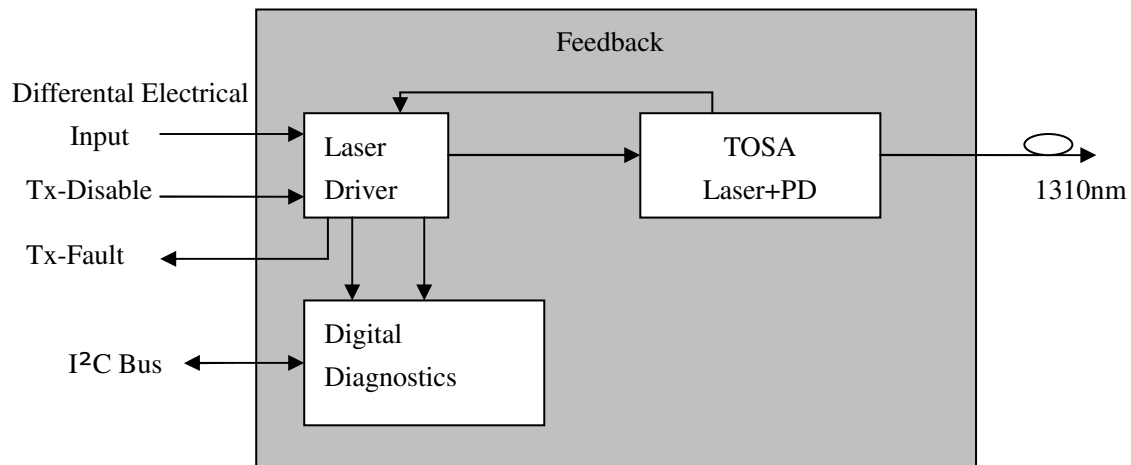

Figure 1: CTP13F5-11-SDI Functional Block Diagram

**Pin Description**

**Pin Out Diagram**

20 VEE	1 VEE
19 TD-	2 Tx-Fault
18 TD+	3 Tx-Disable
17 VEE	4 SDA
16 VCC	5 SCL
15 NC	6 Mod-Def
14 VEE	7 NC
13 NC	8 NC
12 NC	9 VEE
11 VEE	10 VEE

**Pin Function Definitions**

Pin#	Name	Description	Notes
1	VEE	Ground	-
2	TX-Fault	Transmitter Fault Indication	Notes 1
3	TX-Disable	Transmitter Disable	Note 2, Module disables on high or open
4	SDA	I <sup>2</sup> C Data	-
5	SCL	I <sup>2</sup> C Clock	-
6	Mod-Def	Module present indicate	Note 3, Grounded in Module
7	NC	No Connection	-
8	NC	No Connection	-
9	VEE	Ground	-
10	VEE	Ground	-
11	VEE	Ground	-
12	NC	No Connection	-
13	NC	No Connection	-
14	VEE	Ground	-
15	NC	No Connection	-
16	VCC	Transmitter Power	Note 4, 3.3V $\pm$ 5%
17	VEE	Ground	-
18	TD+	Transmit Data In	Note 5
19	TD-	Inv. Transmit Data In	Note 5
20	VEE	Ground	-

**Note:**

- TX-Fault is an open collector/drain output, which should be pulled up with a 4.7K–10K $\Omega$  resistor on the host board. Pull up voltage between 2.0V and VCC+0.3V. When high, output indicates a laser fault of some kind. Low indicates normal operation. In the low state, the output will be pulled to < 0.8V.**
- TX-disable is an input that is used to shut down the transmitter optical output. It is pulled up within the module with a 4.7–10 K $\Omega$  resistor. Its states are:**
  - Low (0 – 0.8V): Transmitter on**
  - (>0.8, < 2.0V): Undefined**
  - High (2.0 – 3.465V): Transmitter Disabled**
  - Open: Transmitter Disabled**
- Mod-Def should be pulled up with a 4.7K – 10K $\Omega$  resistor on the host board. The pull-up voltage shall be VCC. Mod-Def is grounded by the module to indicate that the module is present .**

4. VCC is the transmitter power supplies. It is defined as 3.3V  $\pm$ 5% at the SFP connector pin. Maximum supply current is 300mA. Recommended host board power supply filtering is shown below. Inductors with DC resistance of less than 1  $\Omega$  should be used in order to maintain the required voltage at the SFP input pin with 3.3V supply voltage. When the recommended supply filtering network is used, hotplugging of the SFP transceiver module will result in an inrush current of no more than 30 mA greater than the steady state value.
5. TD-/+: These are the differential transmitter inputs. They are DC-coupled, differential lines with 100  $\Omega$  differential termination inside the module.

## Recommended Host Board Supply Filtering

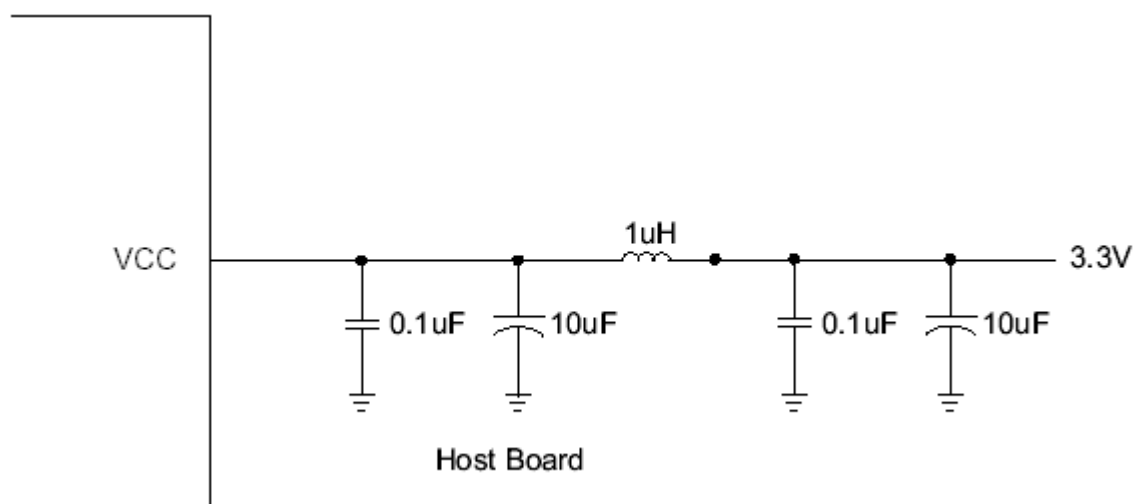

Figure 2: Recommended Host Board Supply Filtering

## Optical Connector Requirements

An LC connector with PC/UPC polish is required for each port.

## Performance Specifications

### Absolute Maximum Ratings

Parameter	Symbol	Min.	Max.	Unit
Storage Temperature	T <sub>ST</sub>	-40	+85	°C
Operating case Temperature	T <sub>case</sub>	-20	+85	°C
Input Voltage	-	GND	VCC	V
Power Supply Voltage	VCC-VEE	-0.5	+3.6	V

**Operating Environment**

Parameter	Symbol	Min.	Max.	Unit
Power Supply Voltage	VCC	+3.1	+3.5	V
Operating Temperature	To	0	+70	°C

**Transmitter E-O characteristics**

Parameter	Symbol	Min.	Typ.	Max.	Unit	Note
Bit Rate	BR	50	-	1500	Mbps	-
Center Wavelength	$\lambda$	1290	1310	1330	nm	-
Spectral Width (RMS)	$\Delta\lambda$	-	-	3	nm	-
Average Optical Output Power	Po	-5	-2	0	dBm	-
Extinction Ratio	ER	5	-	-	dB	-
Power Supply Current	ICC	-	70	180	mA	-
Transmitter Enable Voltage	VEN	0	-	0.8	-	-
Transmitter disable Voltage	VD	2.0	-	VCC	V	-
Data Inputs Voltage	VPP	300	800	1600	mV	-
Optical Rise Time (20%~80%)	Tr	-	170	270	ps	SMPTE 292M 1.485Gbps
		-	300	800	ps	SMPTE 259M 270Mbps
Optical Fall Time (80%~20%)	Tf	-	170	270	Ps	SMPTE 292M 1.485Gbps
		-	300	800	ps	SMPTE 259M 270Mbps
Optical Signal Intrinsic Jitter	-	-	60	100	ps	SMPTE 292M 1.485Gbps
		-	110	180	ps	SMPTE 259M 270Mbps

**EEPROM Section**

The optical transceiver contains an EEPROM. It provides access to sophisticated identification information that describes the transceiver's capabilities, standard interfaces, manufacturer, and other information. The serial interface uses the 2-wire serial CMOS EEPROM protocol defined for the ATMEL AT24C01A/02/04 family of components. When the serial protocol is activated, the host generates the serial clock signal (SCL). The positive edge clocks data into those segments of the EEPROM that are not write protected within the SFP transceiver. The negative edge clocks data from the SFP transceiver. The serial data signal (SDA) is bi-directional for serial data transfer. The host uses SDA in conjunction with SCL to mark the start and end of serial protocol activation. The memories are organized as a series of 8-bit data words that can be addressed individually or sequentially.

The Module provides diagnostic information about the present operating conditions. The transceiver

generates this diagnostic data by digitization of internal analog signals. Calibration and alarm/warning threshold data is written during device manufacture. Received power monitoring, transmitted power monitoring, bias current monitoring, supply voltage monitoring and temperature monitoring all are implemented. The diagnostic data are raw A/D values and must be converted to real world units using calibration constants stored in EEPROM locations 56 – 95 at wire serial bus address A2h. The digital diagnostic memory map specific data field define as following.

**Memory Map:**

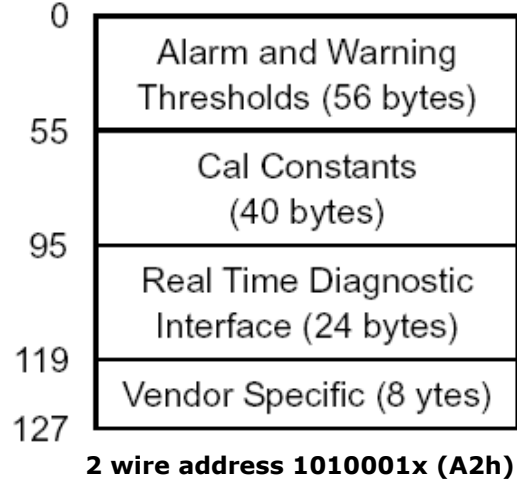
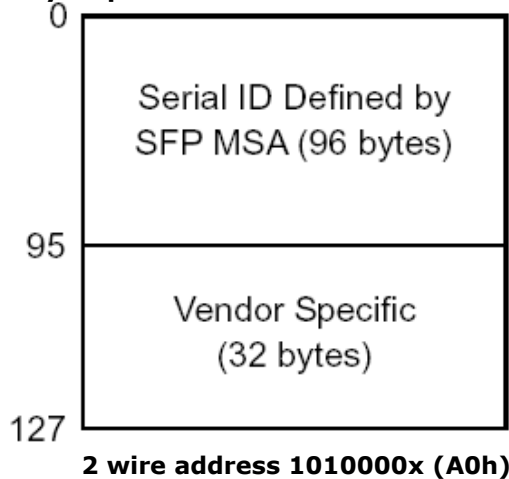

**Recommended Circuit**

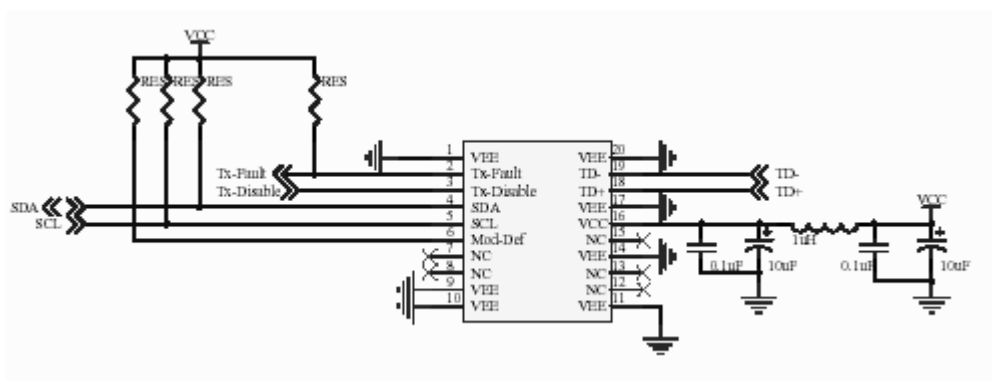

**Note: 4.7K ohms < RES < 10K ohms**

Figure 3: Recommended Circuit

### Package information

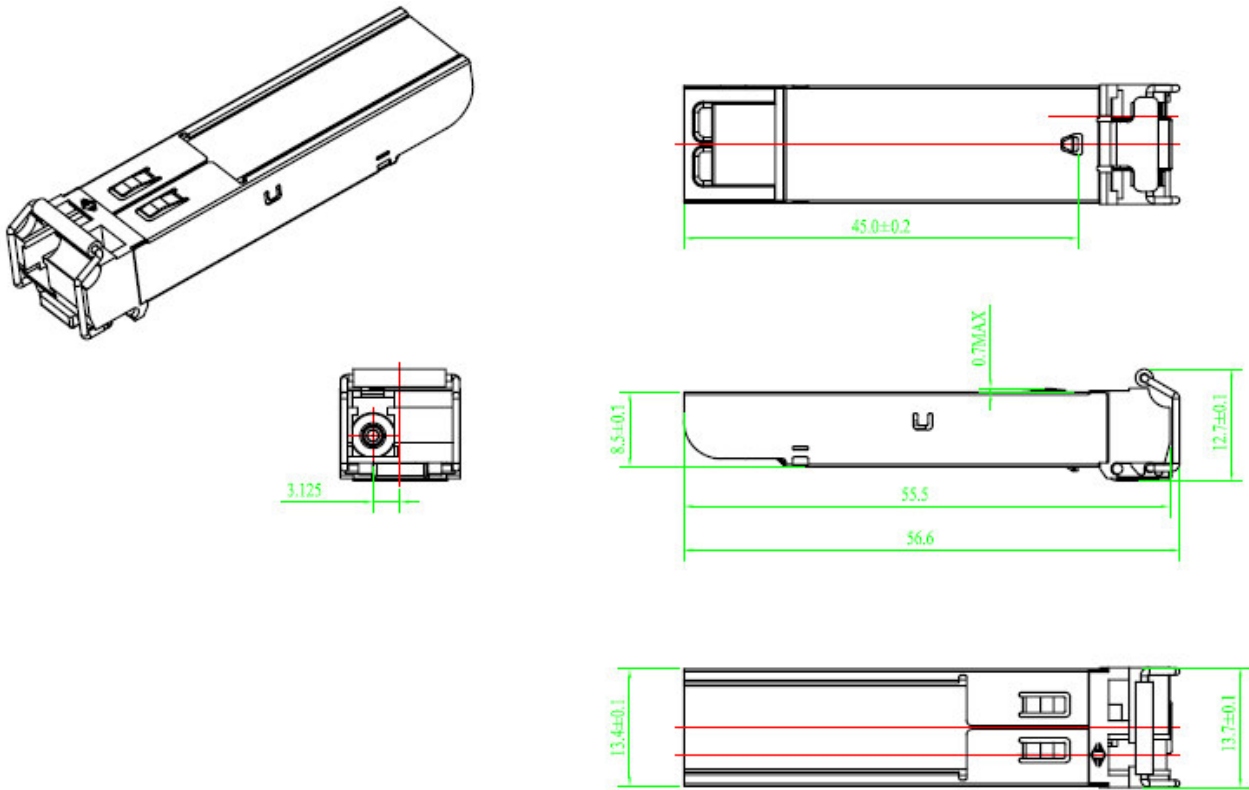

Unit: mm

### For More Information

Shenzhen Transwan Optoelectronic Technology co., Ltd

Add: 5F B Building, Zhi Xuan Han YuanLing Industrial Park, Shi Yan, Bao'an, Shenzhen, P.R.C

Tel: +86-755-29003393, 29003397, 29003396 Fax: +86-755-22630311

E-mail: sales@transwan.com.cn website: www.transwan.com.cn