

10Gb/s 10km Datacom XFP Optical Transceiver

XFP-10G-LR

PRODUCT FEATURES

Supports 9.95Gb/s to 10.5Gb/s bit rates
 Hot-pluggable XFP footprint
 Maximum link length of 10km
 RoHS-6 compliant (lead-free)
 Power dissipation <2.5W
 Temperature range -5°C to 70°C
 No Reference Clock required
 Uncooled 1310nm DFB laser.
 Duplex LC connector
 Built-in digital diagnostic functions

APPLICATIONS

- 10GBASE-LR/LW 10G Ethernet
- 1200-SM-LL-L 10G Fibre Channel

XGIGA's XFP-10GLR Small Form Factor 10Gb/s (XFP) transceivers are compliant with the current XFP Multi-Source Agreement (MSA) Specification¹. The XFP-10GLR complies with 10-Gigabit Ethernet 10GBASE-LR/LW per IEEE 802.3ae and 10G Fibre Channel 1200-SM-LL-L. Digital diagnostics functions are available via a 2-wire serial interface, as specified in the XFP MSA. The transceiver is RoHS compliant and lead free per Directive 2002/95/EC³.

I. Pin Descriptions

Pin	Logic	Symbol	Name/Description	Ref.
1		GND	Module Ground	1
2		VEE5	Optional -5.2 Power Supply – Not required	
3	LVTTL-I	Mod-Desel	Module De-select; When held low allows the module to respond to 2-wire serial interface commands	
4	LVTTL-O	Interrupt	Interrupt (bar); Indicates presence of an important condition which can be read over the serial 2-wire interface	2
5	LVTTL-I	TX_DIS	Transmitter Disable; Transmitter laser source turned off	
6		VCC5	+5 Power Supply	
7		GND	Module Ground	1
8		VCC3	+3.3V Power Supply	
9		VCC3	+3.3V Power Supply	
10	LVTTL-I	SCL	Serial 2-wire interface clock	2
11	LVTTL/O	SDA	Serial 2-wire interface data line	2
12	LVTTL-O	Mod_Abs	Module Absent; Indicates module is not present. Grounded in the module.	2

13	LVTTL-O	Mod_NR	Module Not Ready; XGIGA defines it as a logical OR between RX_LOS and Loss of Lock in TX/RX.	2
14	LVTTL-O	RX_LOS	Receiver Loss of Signal indicator	2
15		GND	Module Ground	1
16		GND	Module Ground	1
17	CML-O	RD-	Receiver inverted data output	
18	CML-O	RD+	Receiver non-inverted data output	
19		GND	Module Ground	1
20		VCC2	+1.8V Power Supply – Not required	
21	LVTTL-I	P_Down/RST	Power Down; When high, places the module in the low power stand-by mode and on the falling edge of P_Down initiates a module reset	
			Reset; The falling edge initiates a complete reset of the module including the 2-wire serial interface, equivalent to a power cycle.	
22		VCC2	+1.8V Power Supply – Not required	
23		GND	Module Ground	1
24	PECL-I	RefCLK+	Reference Clock non-inverted input, AC coupled on the host board – Not required	3
25	PECL-I	RefCLK-	Reference Clock inverted input, AC coupled on the host board – Not required	3
26		GND	Module Ground	1
27		GND	Module Ground	1
28	CML-I	TD-	Transmitter inverted data input	
29	CML-I	TD+	Transmitter non-inverted data input	
30		GND	Module Ground	1

Notes:

- 1 Module circuit ground is isolated from module chassis ground within the module.
- 2 Open collector; should be pulled up with 4.7k – 10kohms on host board to a voltage between 3.15V and 3.6V.
- 3 A Reference Clock input is not required by the XFP-10GLR. If present, it will be ignored.

II. Absolute Maximum Ratings

Parameter	Symbol	Min	Typ	Max	Unit	Ref.
Maximum Supply Voltage 1	Vcc3	-0.5		4.0	V	
Maximum Supply Voltage 2	Vcc5	-0.5		6.0	V	
Storage Temperature	Ts	-40		85	°C	
Case Operating Temperature	TOP	-5		70	°C	

III. Electrical Characteristics (TOP = -5 to 70, Vcc3 = 3.13 to 3.45 Volts)

Parameter	Symbol	Min	Typ	Max	Unit	Ref.
Main Supply Voltage	Vcc5	4.75		5.25	V	
Supply Voltage #2	Vcc3	3.13		3.45	V	
Supply Current – Vcc5 supply	Icc5			320	mA	

Supply Current – Vcc3 supply	Icc3			265	mA		
Module total power	P			2.5	W	1	
Transmitter							
Input differential impedance	R _{in}		100		Ω	2	
Differential data input swing	V _{in,pp}	120		820	mV		
Transmit Disable Voltage	V _D	2.0		V _{cc}	V	3	
Transmit Enable Voltage	V _{EN}	GND		GND+ 0.8	V		
Transmit Disable Assert Time				10	us		
Receiver							
Differential data output swing	V _{out,pp}	340	650	850	mV	4	
Data output rise time	t _r			38	ps	5	
Data output fall time	t _f			38	ps	5	
LOS Fault	V _{LOS fault}	V _{cc} – 0.5		V _{CCHOST}	V	6	
LOS Normal	V _{LOS norm}	GND		GND+0.5	V	6	
Power Supply Rejection	PSR	See Note 6 below					7

Notes:

- 1 Maximum total power value is specified across the full temperature and voltage range.
- 2 After internal AC coupling.
- 3 Or open circuit.
- 4 Into 100 ohms differential termination.
- 5 20 – 80%
- 6 Loss Of Signal is open collector to be pulled up with a 4.7k – 10kohm resistor to 3.15 – 3.6V. Logic 0 indicates normal operation; logic 1 indicates no signal detected.
- 7 Per Section 2.7.1. in the XFP MSA Specification¹.

IV. Optical Characteristics (T_{OP} = -5 to 70, V_{CC3} = 3.13 to 3.45 Volts)

Parameter	Symbol	Min	Typ	Max	Unit	Ref.	
Transmitter							
Optical Modulation Amplitude (OMA)	P _{OMA}	-4.8			dBm		
Maximum Launch Power	P _{MAX}			0.5	dBm		
Optical Wavelength	λ	1260		1355	nm		
Sidemode Supression ratio	SSR _{min}	30			dB		
Optical Extinction Ratio	ER	3.5			dB		
Transmitter and Dispersion Penalty	TDP			3.2	dB		
Average Launch power of OFF transmitter	P _{OFF}			-30	dBm		
Tx Jitter	T _{Xj}	Per 802.3ae requirements					
Relative Intensity Noise	RIN			-130	dB/Hz		
Receiver							
Receiver Sensitivity (OMA) @ 10.5Gb/s	R _{SENS1}			-12.6	dBm	1	
Stressed Receiver Sensitivity (OMA) @ 10.5Gb/s	R _{SENS2}			-10.3	dBm	2	
Maximum Input Power	P _{MAX}	+0.5			dBm		
Optical Center Wavelength	λ _C	1260		1600	nm		

Receiver Reflectance	R _{rx}			-12	dB	
LOS De-Assert	LOS _D			-18	dBm	
LOS Assert	LOS _A	-32			dBm	
LOS Hysteresis		0.5			dB	

Notes:

- 1 Measured with worst ER; BER < 10⁻¹²; 2³¹ – 1 PRBS.
- 2 Per IEEE 802.3ae. Equivalent to –13.3 dBm average power at Infinite ER.

V. General Specifications

Parameter	Symbol	Min	Typ	Max	Units	Ref.
Bit Rate	BR	9.95		10.5	Gb/s	1
Bit Error Ratio	BER			10 ⁻¹²		2
Max. Supported Link Length	L _{MAX}		10		km	1

Notes:

- 1 10GBASE-LR/LW, 1200-SM-LL-L.
- 2 Tested with a 2³¹ – 1 PRBS

VI. Environmental Specifications

XGIGA XFP transceivers have an operating temperature range from -5°C to +70°C case temperature.

Parameter	Symbol	Min	Typ	Max	Units	Ref.
Case Operating Temperature	T _{op}	-5		70	°C	
Storage Temperature	T _{sto}	-40		85	°C	

VIII. Digital Diagnostic Functions

As defined by the XFP MSA¹, XGIGA XFP transceivers provide digital diagnostic functions via a 2-wire serial interface, which allows real-time access to the following operating parameters:

- Transceiver temperature
- Laser bias current
- Transmitted optical power
- Received optical power
- Transceiver supply voltage

It also provides a sophisticated system of alarm and warning flags, which may be used to alert end-users when particular operating parameters are outside of a factory-set normal range.

The operating and diagnostics information is monitored and reported by a Digital Diagnostics Transceiver Controller (DDTC) inside the transceiver, which is accessed through the 2-wire serial interface. When the serial protocol is activated, the serial clock signal (SCL pin) is generated by the host. The positive edge clocks data into the XFP transceiver into those segments of its memory map that are not write-protected. The negative edge clocks data from the XFP transceiver. The serial data signal (SDA pin) is bi-directional for serial data transfer. The host

uses SDA in conjunction with SCL to mark the start and end of serial protocol activation. The memories are organized as a series of 8-bit data words that can be addressed individually or sequentially. The 2-wire serial interface provides sequential or random access to the 8 bit parameters, addressed from 000h to the maximum address of the memory.

For more detailed information including memory map definitions, please see XGIGA Application Note AN-2035 “Digital Diagnostic Monitoring Interface for XFP Optical Transceivers”, or the XFP MSA Specification.

IX. Mechanical Specifications

XGIGA’s XFP transceivers are compliant with the dimensions defined by the XFP Multi-Sourcing Agreement (MSA).

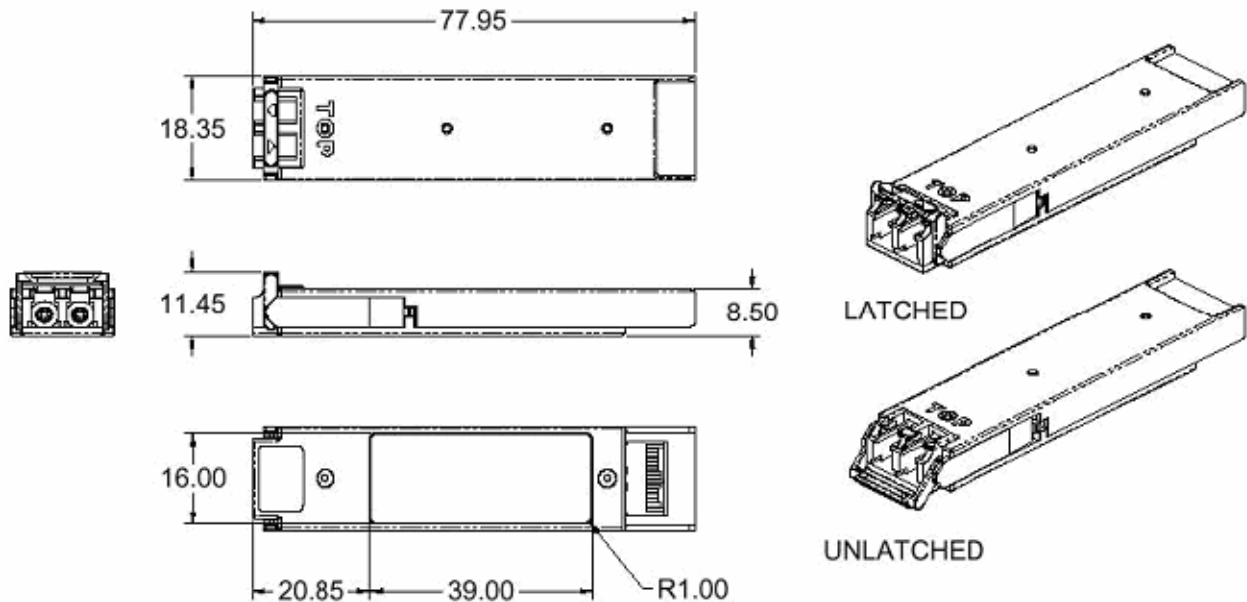

XFP Transceiver (dimensions are in mm)