

# SFP-550

## Maintenance Manual



296-1 MATSUHIDAI, MATSUDO-CITY, CHIBA 270-2214 JAPAN

TEL: +81-47-388-6111 FAX: +81-47-388-4477

## **Introduction**

This manual covers items and procedures for the periodic inspection required for the SFP-550 Polishing Machine. At the periodic inspection or in the event of problems arising, read this manual and familiarize yourself with the machine before maintaining it. Make sure that power is off when performing inspections or maintenance on the machine.

### **Note**

This manual covers maintenance of the SFP-550 when used in accordance with SFP-550 Polishing Machine Operating Manual. Read the Operating Manual and the Polishing Process Manual along with this manual also. Please contact us or our agents if you have any question or problem not covered by this manual.

~~~~~ Contents ~~~~~

- 1 Inspection**
  - 1-1 Functioning Inspection** ----- **3**
  
  - 1-2 Regular inspection and maintenance**
    - 1-2-1 Grease check in the drive unit ----- **5**
    - 1-2-2 Dimension check for the turntable and others
    - 1-2-3 Pressurizing unit check
  
- 2 Treatment for unusual conditions**
  - 2-1 Unusual sound** ----- **10**
    - 2-1-1 Eccentric ring checking
  
  - 2-2 The turntable doesn't move smoothly** ----- **11**
    - 2-2-1 Gear unit checking
    - 2-2-2 Eccentric plates removal
  
- 3 Mechanical Structure**
  - 3-1 Mechanical Components** ----- **13**
  
  - 3-2 Structure Schematic** ----- **15**

## 1 Inspection

### 1-1 Functioning Inspection

At the first starting or operating the machine after your purchase or any problem arising, conduct performance inspection as outlined below.

#### Power cable plugging

Make sure an adaptation of electrical specifications before plugging in a power cable.

#### Timer setting

Make sure the scales on the timer are set as [min] and [\*1]

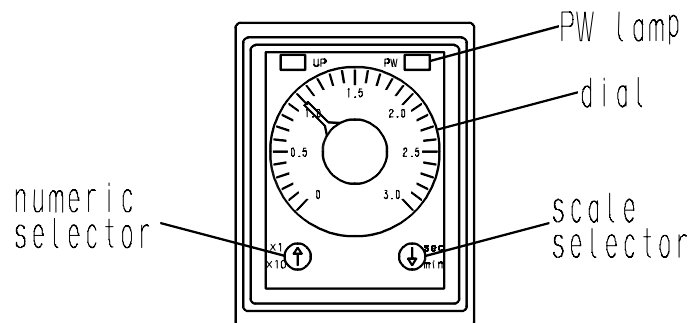

### Power Switch ON

- Does the pilot lamp (red) light on?
- Is the cooling fan running?

### Timer Switch ON

- Does the [PW] lamp on the timer light on?
- Do the pilot lamp (red and green) light on?
- Does the turntable begin revolution and rotation?
- Does the cooling fan keep running?

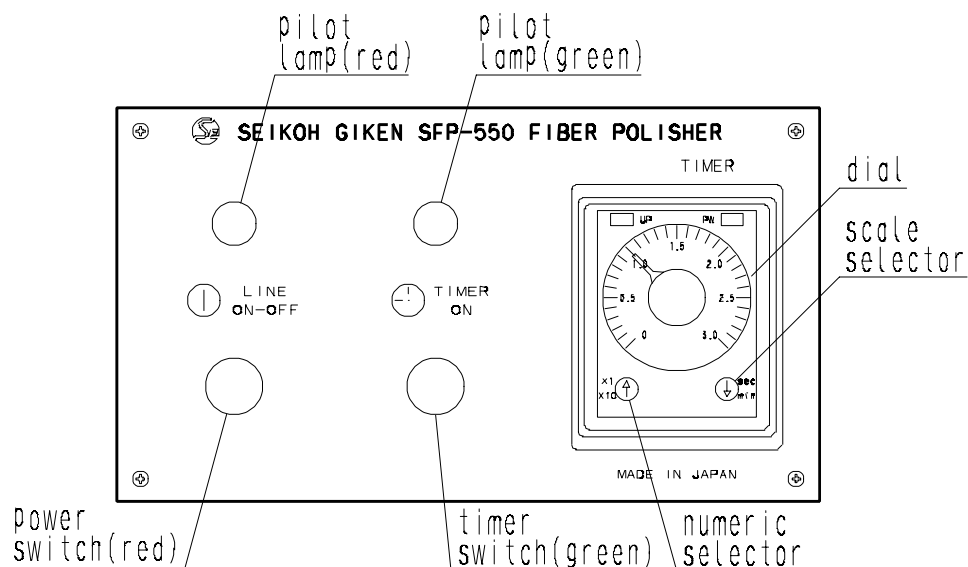

### Time Up

- Does the [PW] lamp on the timer go out?
- Does the pilot lamp (red) go out?
- Does the turntable stop revolution and rotation?
- Does the cooling fan keep running?

### Power Switch OFF

- Do all the lamps on the front panel go out?
- Does the cooling fan stop running?

## 1-2 Regular inspection and maintenance

Critical points in a principle of polishing with SFP-550 Polishing Machine are following:

1. Polishing track of ferrule by revolution and rotation of the turntable
2. Pressure of polishing (the space between the clamping posts on the four corners and the turntable, the protrusion length of ferrules from the bottom side of the polishing holder)

Read and familiarize yourself with the followings before inspection.

### **1-2-1 Grease check in the drive unit (once a month or for every 100-500 driving hours)**

Remove the turntable and check the drive unit if it is full up with grease.

See Figure 1-2-1.

### **1-2-2 Dimension check for the turntable and others (once for 3 months or for 500-1000 driving hours)**

Check the space between the clamping posts on the four corners and the turntable.

\*The space between each clamping post and the turntable:  $5.5\pm 0.02\text{mm}$

See Figure 1-2-2.

### **1-2-3 Pressurizing unit check (once for 6 months or for every 1000-2000 driving hours)**

Check the free length of the pressurizing coil springs installed in the clamping posts.

\*The free length of the pressurizing coil springs (P/N: RP55-20):  $14.5\text{mm or more}$

See Figure 1-2-3.

**Figure 1-2-1: Grease check in the drive unit**

The turntable can be removed as it is lifted up.

- Make sure that the drive unit is full up with grease.
- If there is any space in the hatching part of the figure below, fill it up with the grease (FP-GS).

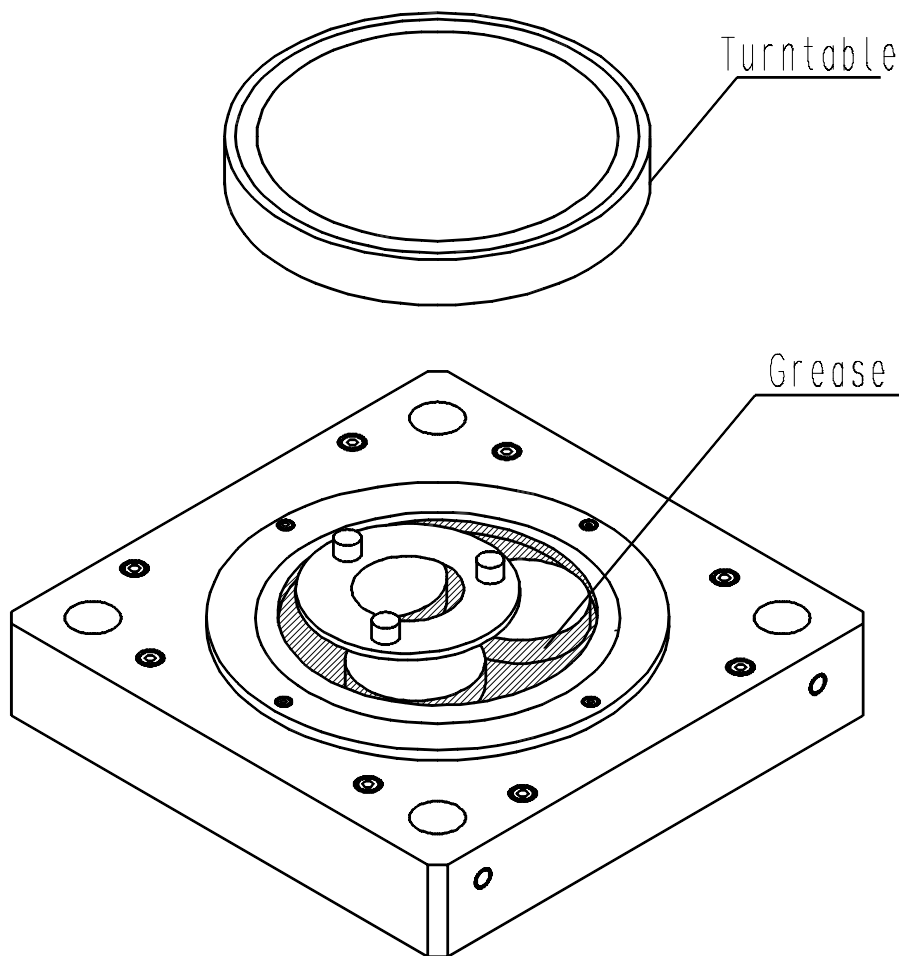
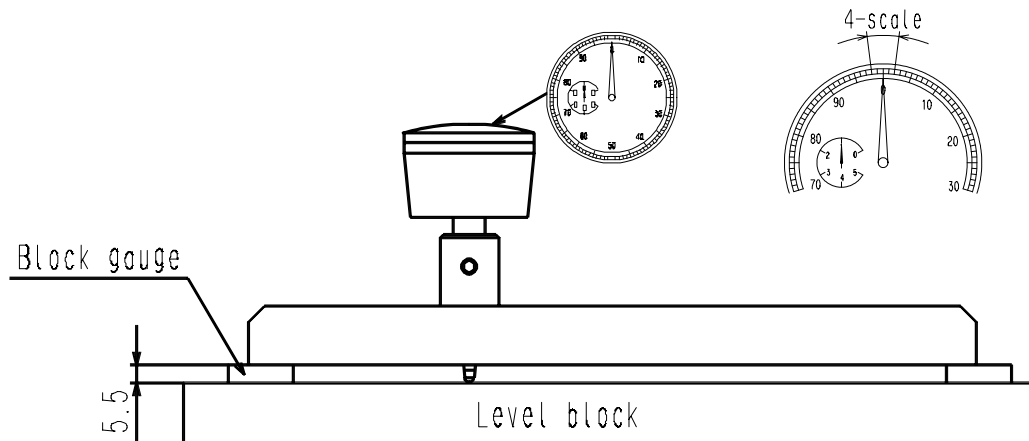

**Figure 1-2-2: Dimension check for the turntable and others**

We provide the height gauge(P/N: FP-HG55) for this inspection as the optional tool.

**Reference**

- Place the 5.5mm-block gauge and the height gauge on the level block and set the dial of the height gauge as the hand comes to zero.



**Measurement**

- Place the gauge on the clamping posts diagonally and check each four posts. Make sure that the space on each points is within the specification of **5.50mm+/-0.02mm**. At the scale indication, the specification value is 0(Zero)+/-2. If the measurement result is out of this specification at the scale indication, adjust the space in accordance with the followings.

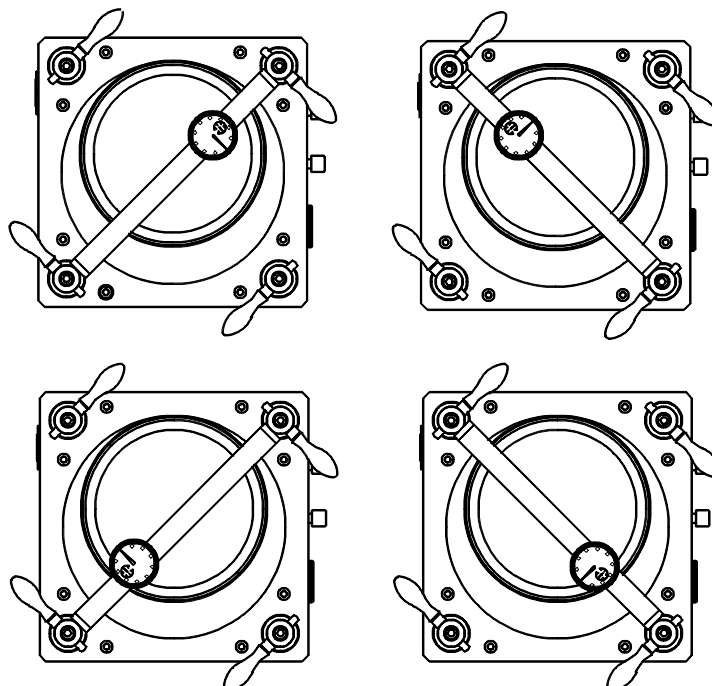

Adjustment

Adjust the space between the clamping posts and the turntable, if it is out of the specification value, in accordance with the following procedure.

- Loosen the set screws on the side of the base plate (two screws for each clamping post).
- Remove the clamping post (pressurizing) unit and spacer.
- Measure the thickness of the spacer, t.

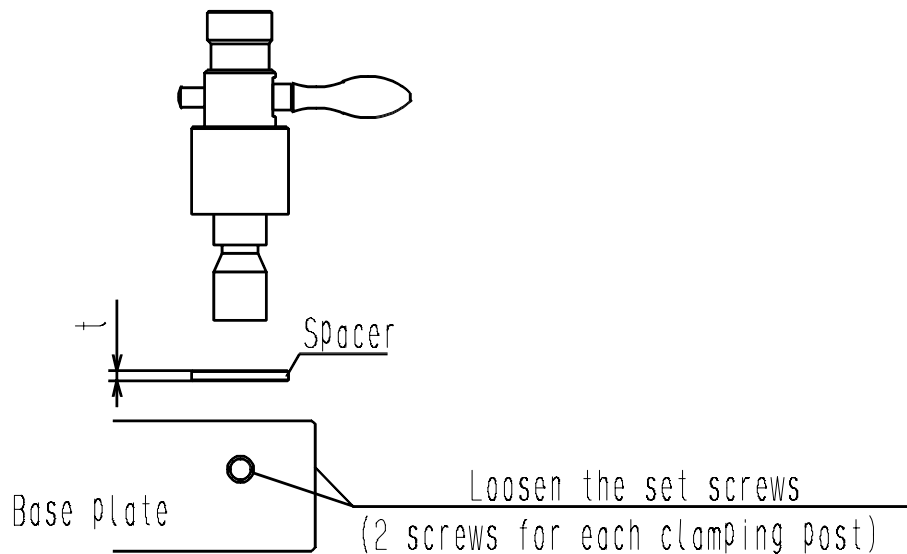

- Calculate the required thickness of the spacer, with the former measurement result of the spacer, t, in accordance with the following expression.

**Required thickness of the spacer = Space between the turntable and clamping post + the thickness of the present spacer, t**

Example:

Space between the turntable and clamping post: 4-scale to minus (-0.04mm)  
and the thickness of the present spacer, t: 3.00mm, then  
Required thickness of the spacer = (-0.04mm) + 3.00mm = 2.96mm

Repeat this procedure for all four clamping posts each.

- When you order the spacer (RP55-16), please designate the thickness of the spacer.

**Figure 1-2-3: Pressurizing unit check**

- Loosen the retaining screws on the side of the clamping posts (2 screws for each post) and remove the pressure adjustment bolt.
- Remove the pressurizing coil springs and measure its free length.

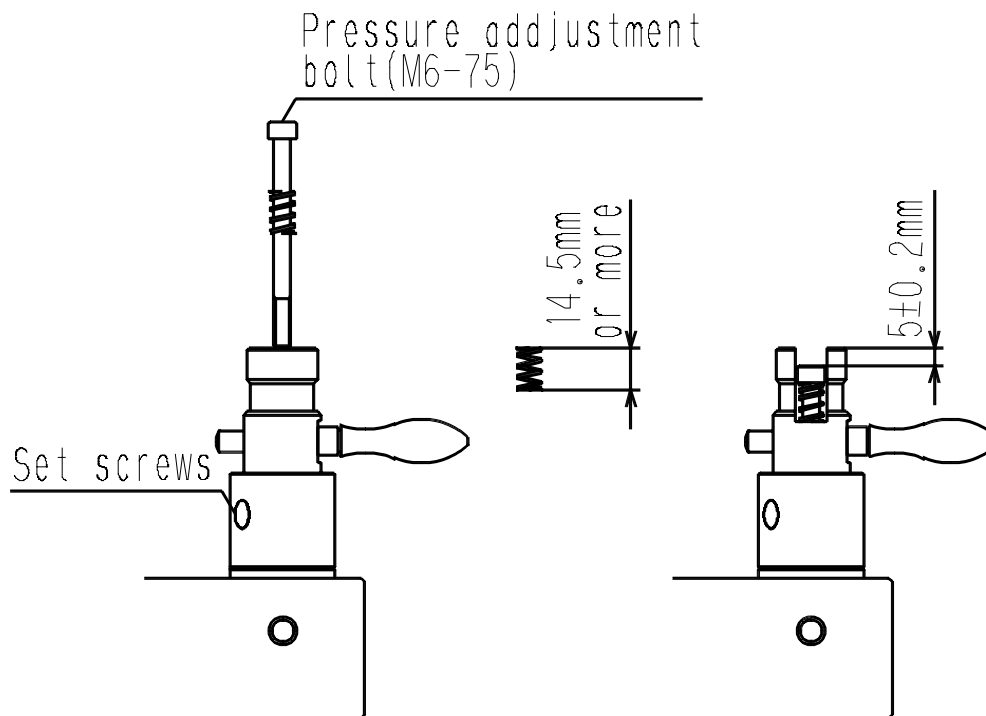

**Specification for the free length of the coil spring: Min. 14.5mm(with no pressure)**

- If the free length of the pressurizing coil spring (RP55-20) is out of the specification, exchange it for new one.
- When you tighten the pressure adjustment bolt, adjust the length between the bolt head and the upper plane of the clamping post as 5+/-0.2mm (see the right figure above).
- When you tighten the pressure adjustment bolts, tighten both bolts evenly from the both side of the clamping post. If the bolts are tightened unevenly, the clamping levers do not move smoothly.

## 2 Treatment for unusual conditions

### CAUTION

Make sure the power cable is unplugged while the inspection and the maintenance.

### 2-1 Unusual sound is occurred while the machine is driving.

Check wear-outs in the drive unit.

#### 2-1-1 Eccentric plates checking

The turntable and the position plate can be removed as they are lifted up.

- Make sure that no large scratch or wear-out on the three eccentric plates.
- Make sure that no large scratch, bend, distortion, or wear-out on the upper side of the supporting ring.
- If there is any large scratch or wear-out on the eccentric plate (RP-55-05) and the supporting ring (RP55-03), exchange them for new ones.

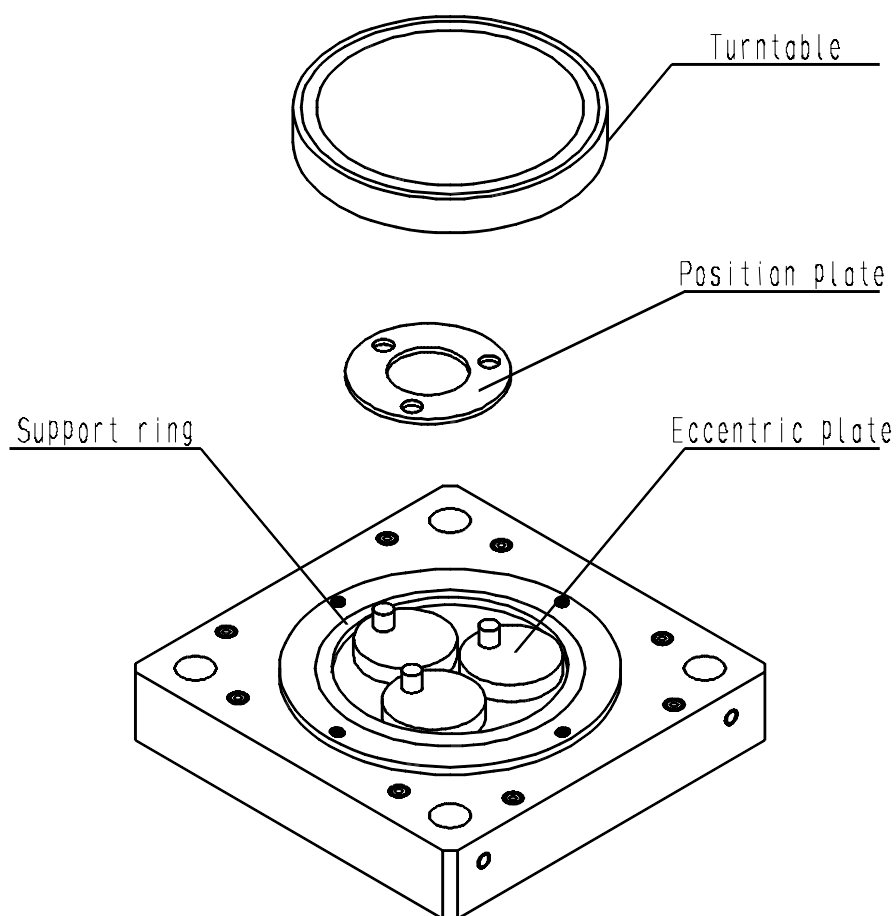

**2-2 The turntable doesn't move smoothly while the machine is driving.  
Check wear-outs in the drive unit.**

**2-2-1 Gear unit checking**

The gear unit can be removed as it is lifted up by the center hole of the 100T gear or the eccentric plates, after the supporting ring is removed.

- Make sure that no large scratch, bend, distortion, or wear-out on the bottom side of a supporting ring.
- Make sure that no large scratch, bend, or distortion on the upper and bottom side of the 100T gear.
- Make sure that the bearings attached to the bottom of the turntable moves smoothly.

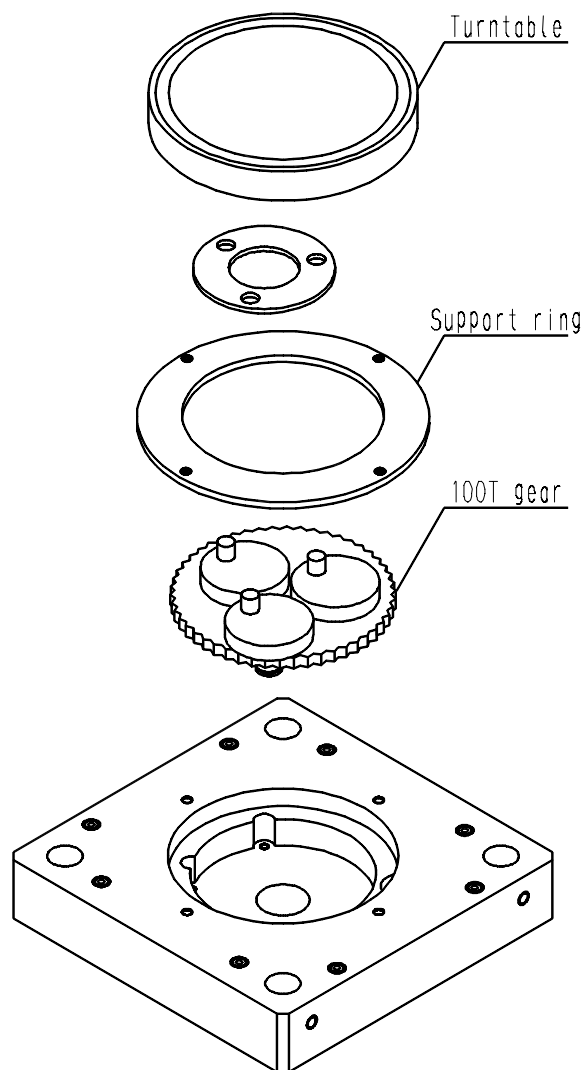

**2-2-2 Eccentric plates removal**

Check the bearings when the eccentric plates do not rotate smoothly. Remove the eccentric plates from the 100T gear. The eccentric plates are attached by C-rings on the bottom side of the 100T gear. To take off the c-rings, use the tool generally on the market.

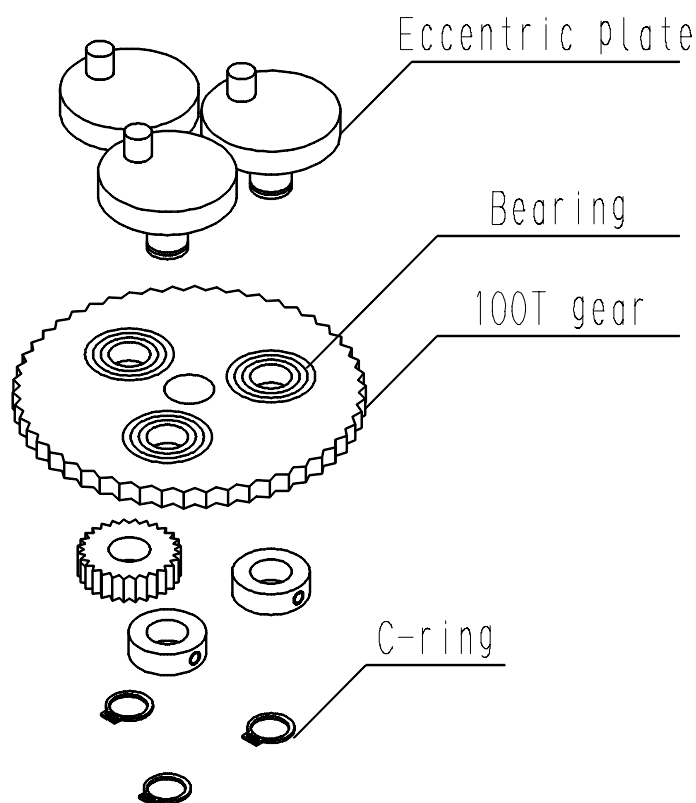

- Make sure that inner hole of bearings for the eccentric plates rotate smoothly.

The bearings need to be replaced when the bearings under the turntable and in the 100T gear do not move smoothly. Tools, such as a bearing puller and a press are needed to replace the bearings. Please ask us or our agents if there is any difficulty on the bearing replacement.

### 3 Mechanical Structure

#### 3-1 Mechanical components

| #  | Part No. | Description                                                              | Q'ty/set |
|----|----------|--------------------------------------------------------------------------|----------|
| 1  | RP55-01  | 5-Inch turntable for SFP-550                                             | 1        |
|    |          | Bearing for turntable                                                    | 3        |
| 3  | RP55-03  | Support ring for SFP-550/520                                             | 1        |
| 4  | RP55-04  | Position plate for SFP-550/520                                           | 1        |
| 5  | RP55-05  | Eccentric drive ring for SFP-550/520<br>(including knock pin)            | 3        |
| 6  | RP55-06  | 100T Gear for SFP-550/520                                                | 1        |
|    |          | Bearing for 100T gear                                                    | 3        |
| 8  | RP55-08  | 28T Gear for SFP-550/520                                                 | 1        |
| 9  | RP55-09  | Retaining collar for SFP-550/520                                         | 2        |
| 10 | RP55-10  | C-ring for SFP-550/520/510                                               | 3        |
| 11 | RP55-11  | 14T Gear for SFP-550/520                                                 | 1        |
| 12 | RP55-12  | 6W Motor & Gear box for SFP-550/520/510<br>(including "M4-L65"bolt 4pcs) | 1        |
| 13 | RP55-13  | 20T Gear for SFP-550/520                                                 | 1        |
| 14 | RP55-14  | 15W Motor & Gear box for SFP-550/520<br>(including "M5-L50"bolt 4pcs)    | 1        |
| 15 | RP55-15  | Supporting Ccolumn for SFP-550/520                                       | 8        |
| 16 | RP55-16  | Adjustment spacer                                                        | 4        |
| 17 | RP55-17  | Clamp rod                                                                | 4        |
| 18 | RP55-18  | Clamp pin<br>(including knock pin)                                       | 4        |
| 19 | RP55-19  | Clamp lever for SFP-550                                                  | 4        |
| 20 | RP55-20  | Coil spring for SFP-550                                                  | 4        |
| 21 | RP55-21  | Cable support rod A                                                      | 1        |
| 22 | RP55-22  | Strut clamp                                                              | 1        |
| 23 | RP55-23  | Cable support rod B                                                      | 1        |
| 24 | RP55-24  | Cable hook                                                               | 1        |
| 25 | RP55-25  | Cooling fan for SFP-550<br>(including electrical cord , fan guard)       | 1        |
| 26 | RP55-26  | Power switch for SFP-550                                                 | 1        |
| 27 | RP55-27  | Timer switch for SFP-550                                                 | 1        |
| 28 | RP55-28  | Timer for SFP-550                                                        | 1        |
| 29 | RP55-29  | Locate pin for SFP-550/520                                               | 1        |
| 30 | RP55-30  | Power cord for SFP-550/520                                               | 1        |
| 31 | RP55-31  | M6-L75 Allen hex socket screw                                            | 4        |
| 32 | RP55-32  | M5-L15 Allen hex socket screw                                            | 8        |
| 33 | RP55-33  | M5-L10 Allen hex socket screw                                            | 8        |
| 34 | RP55-34  | M4-L15 Allen hex socket screw                                            | 4        |
| 35 | RP55-35  | M3-L8 Allen hex socket screw                                             | 4        |
| 36 | RP55-36  | M4-L10 Cross recessed head screw                                         | 4        |
| 37 | RP55-37  | M3-L8 Cross recessed head screw                                          | 9        |

**SFP-550 Maintenance Manual**  
**FP-MM55 Issue1**

|    |         |                                  |    |
|----|---------|----------------------------------|----|
| 38 | RP55-38 | M8-L8 Clamping screw (ball type) | 4  |
| 39 | RP55-39 | M5-L5 Set screw                  | 14 |
| 40 | RP55-40 | M4 Nut                           | 3  |
| 41 | RP55-41 | M3 Nut                           | 3  |
| 42 | RP55-42 | M4 Washer                        | 15 |
| 43 | RP55-43 | M3 Washer                        | 3  |

3-2 Structure Schematic

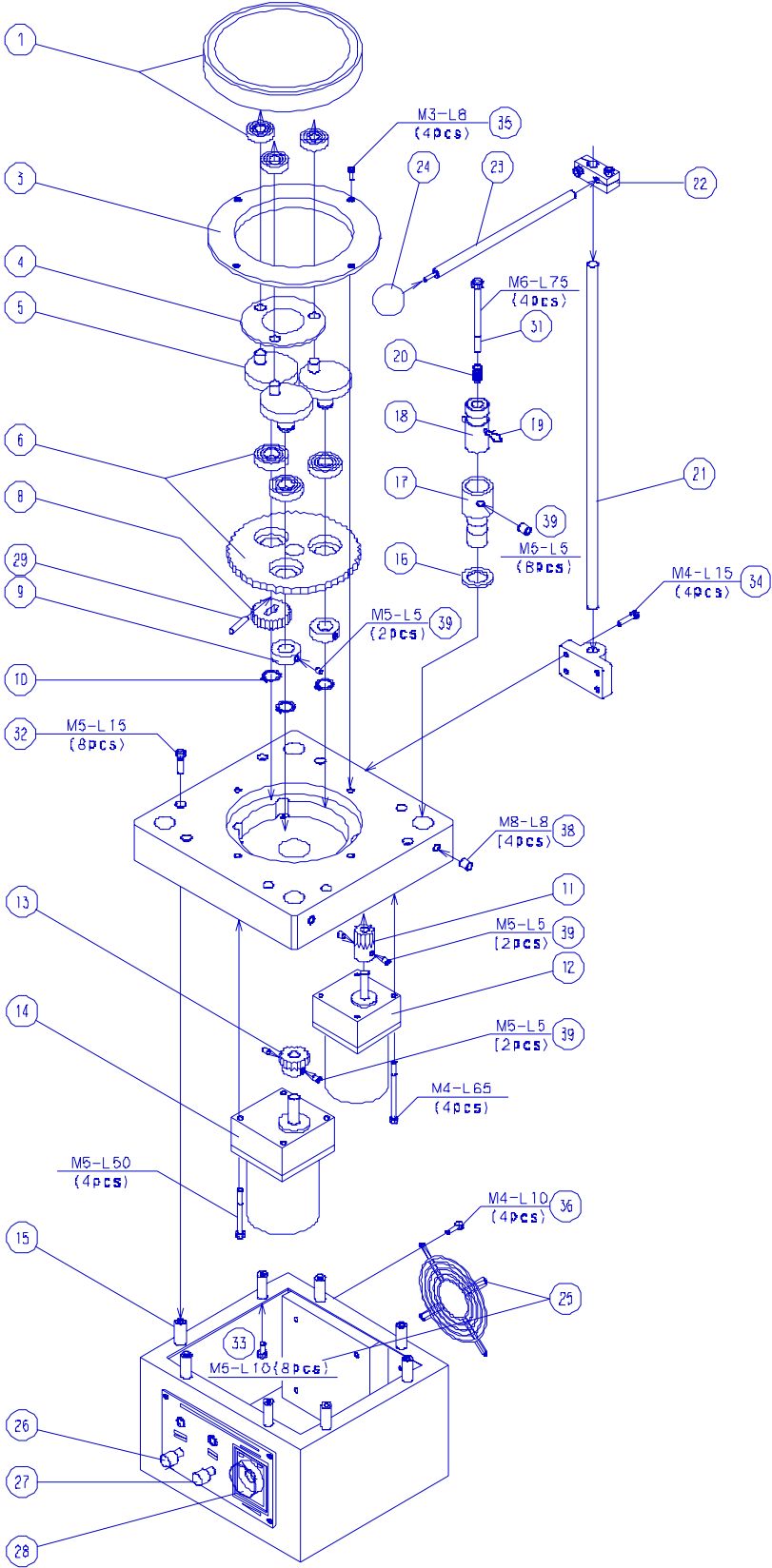

Mar 01 2002  
SFP-550 Maintenance Manual  
FP-MM55