

# SFP-550

## Operating Manual



---

296-1 MATSUHIDAI, MATSUDO-CITY, CHIBA 270-2214 JAPAN  
TEL: +81-47-388-6111 FAX: +81-47-388-4477

## Safety Precautions

To ensure safe operation and maximize product service life, observe the following precautions:

- Wear safety shoes and clothes appropriate for safe operation. Take caution to avoid getting clothes or hair caught in the machine.
- Install the machine on a workbench with sufficient strength to support it. Keep the machine level and stableness in order to keep it from tipping over or falling off the workbench.
- Use the rated power supply indicated on the machine.
- Use a 2A fuse. Make sure the machine is unplugged when changing fuses.
- Ground the machine to prevent electric shock before you turn on the power. Never touch the machine when your hands are wet.
- Never touch rotating parts while the machine is running. Make sure the machine has come to a full stop before changing the polishing holder. Always turn off the power and unplug the machine when leaving the machine.
- To prevent rusting, immediately wipe the unit dry after you turn off the power. Never use or store the unit in very humid environment.
- Do not use the machine under unattended operation. Make sure the power is off while leaving.
- Keep the machine away from inflammables, chemicals, and explosives.
- Do not disassemble or make any modifications to the machine. Do not place foreign substances or objects inside the machine.
- Maintain a clear space of at least 30cm from the cooling fan outlet.
- During transportation, take extra precaution not to drop the unit. In general, avoid subjecting the machine to any shock or damage.
- If the machine overheats, makes unusual noises, or gives off smoke or unusual odors, immediately stop using and unplug the machine. Then contact us or your nearest agent.
- Use only the accessories and consumables specified by the manufacturer.
- To ensure safe and correct operation, read the Process Manual and the Maintenance Manual along with this Operating Manual before using the machine.

## Introduction

- Thank you for purchasing SFP-550 Polishing Machine -

This operating manual covers operating procedures for SFP-550 Polishing Machine in depth. Before use, read this manual carefully and familiarize yourself with the various features and functions of this machine.

## Features of SFP-550

Designed to polish the ferrule endfaces of fiber-optic connectors, the SFP-550 offers the following features:

### **High-Yield Operation**

Capable of quick polishing up to many ferrules\* at once. (\* The number of ferrules varies slightly depending on the types of connectors.)

### **Easy Operation**

Both maintenance and operation are remarkably easy and require no special skills.

### **Wide Range of Application**

Applicable to FC, SC, and various other connector types in high-physical contact, angled physical contact or flat contact, simply by changing the polishing holder.

~~~~~ Contents ~~~~~

§ 1. Specifications

|     |                         |   |
|-----|-------------------------|---|
| 1.1 | Structure and Parts     | 4 |
| 1.2 | Standard specifications | 6 |
| 1.3 | Standard Accessories A  | 7 |

§ 2. Operating Procedures

|     |                               |    |
|-----|-------------------------------|----|
| 2.1 | Operating Panel               | 9  |
| 2.2 | Turntable Assembly            | 10 |
| 2.3 | Polishing Materials           | 11 |
| 2.4 | Polishing Holder              | 13 |
| 2.5 | Pressurizing and Holding Unit | 14 |
| 2.6 | Operating Manual              | 14 |

§ 1. Specifications

**1.1 Structure and Parts**

Polishing Machine Top View

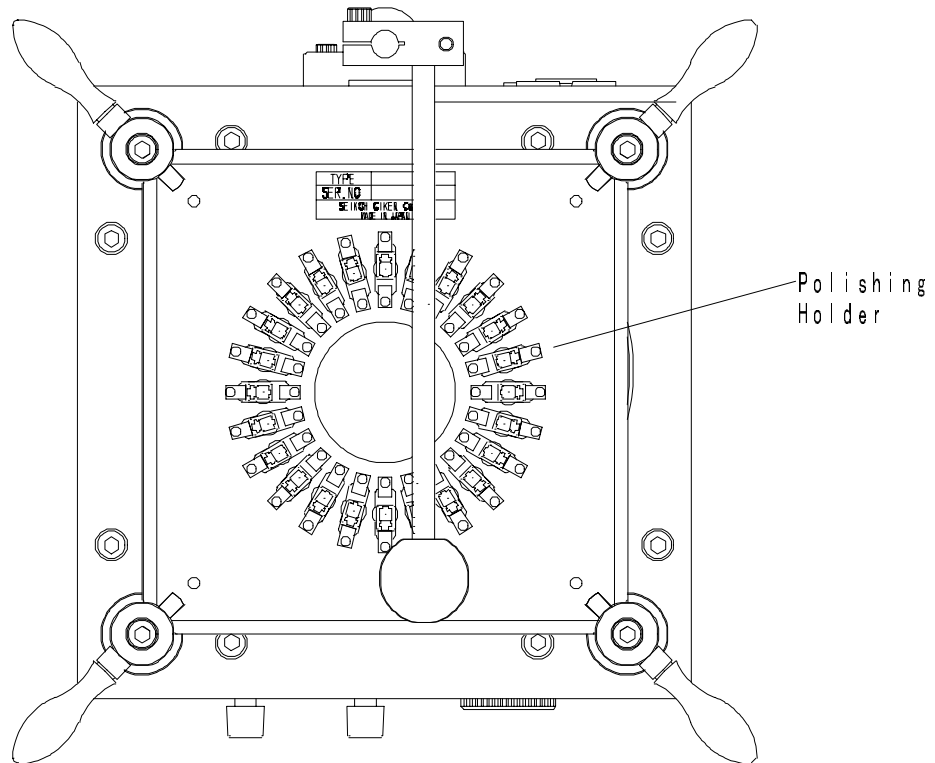
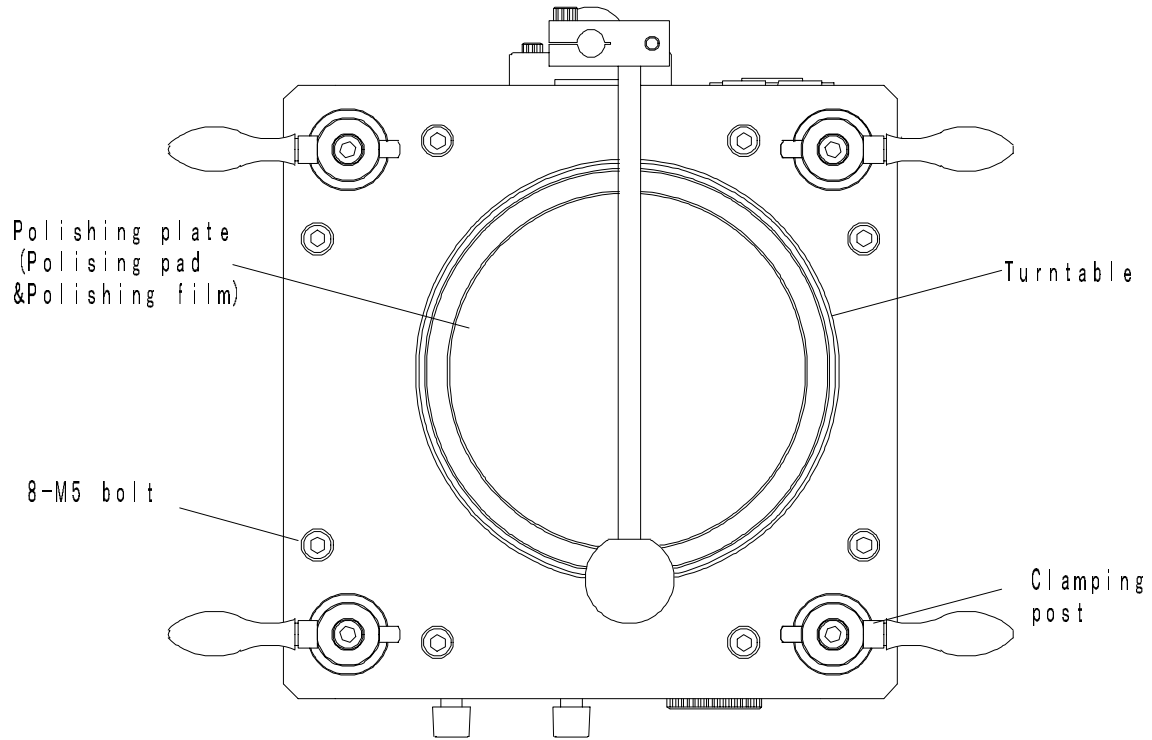

Polishing Machine Front View

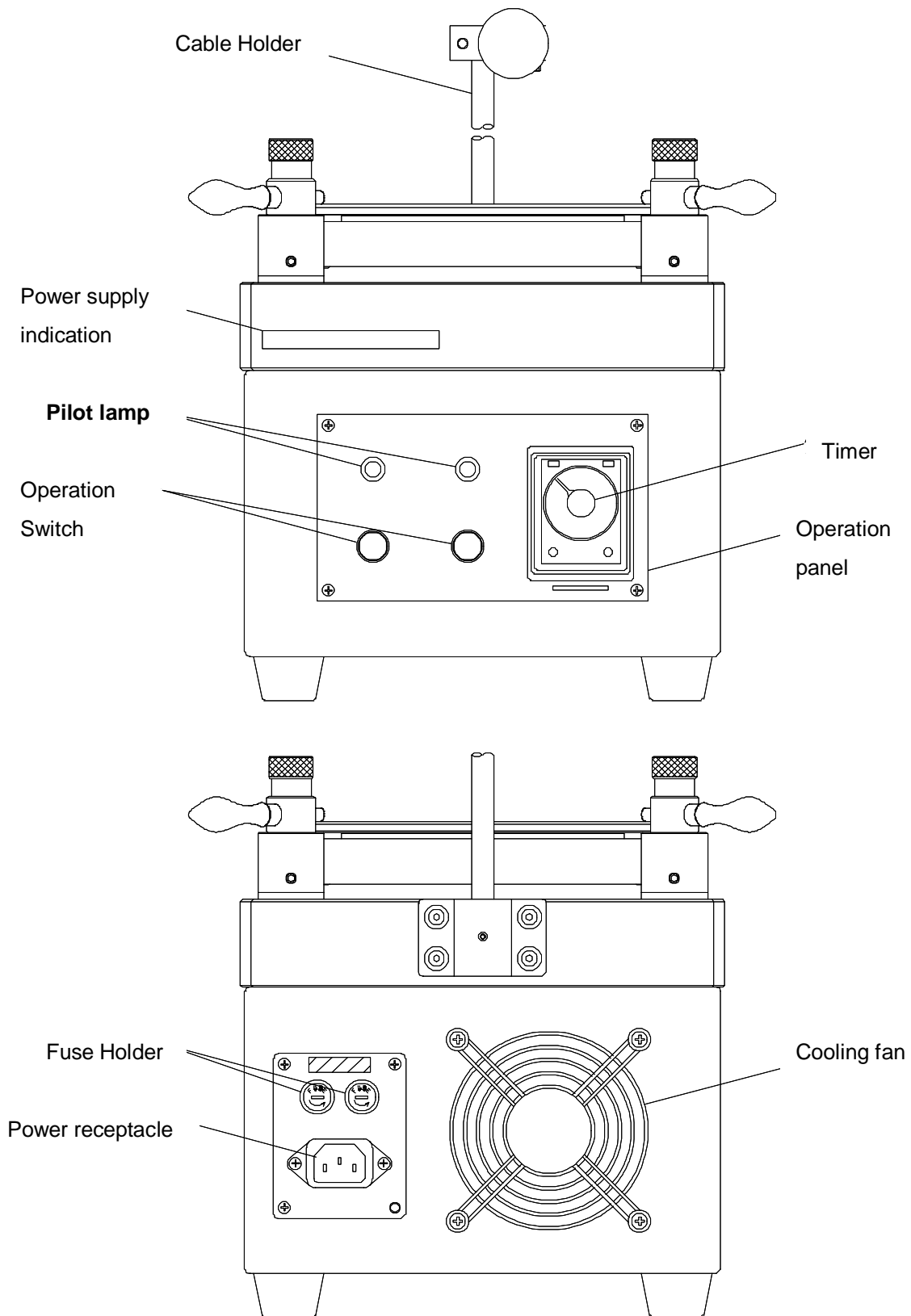

## 1.2 Standard Specifications

| Item                                                                                          | Specification                                                                                                                                      |
|-----------------------------------------------------------------------------------------------|----------------------------------------------------------------------------------------------------------------------------------------------------|
| Power Supply<br>Voltage, Frequency<br><br>Power Consumption                                   | AC110—120V: 50Hz/60Hz or<br>AC220—240V: 50Hz<br>80VA                                                                                               |
| Drive Unit<br>Revolution Motor (rpm)<br><br>Rotation Motor (rpm)<br>Cooling Fan               | 15W Motor with reduction gear<br>(70rpm)<br>6W Motor with reduction gear (1rpm)<br>φ90mm propeller fan                                             |
| Operating Unit<br>Control Timer<br><br>Power Switch<br>Timer Switch                           | Setting increment: 0.1minutes<br>Maximum setting time: 3.0 minutes<br>Red-lamp button(on-off alternately)<br>Green-lamp button(on-off alternately) |
| Pressurizing Unit<br>Pressurizing Method                                                      | By clamps on the four corner with coil spring                                                                                                      |
| Polishing Plates<br>Polishing Film<br>Polishing Pad<br>For Flat Polishing<br>For PC Polishing | Outer diameter: 127mm, plastic base<br>Outer diameter: 127mm<br>glass pad<br>Synthetic rubber pad                                                  |
| Performance<br>PC Polishing(Pre-DomeFerrule)<br>APC Polishing(StepFerrule)                    | 4 processes, 1.4~2.4 minutes<br>5 processes, 3.0~5.0 minutes                                                                                       |
| Dimensions and Weight<br>Dimensions<br>Weight                                                 | W230 × D230 × H255 mm<br>23.5 kg                                                                                                                   |

**\*Above specifications are subjected to change without notice.**

### 1.3 Standard Accessories

| Description                                 | Part No.    | Qty |
|---------------------------------------------|-------------|-----|
| Polishing Pad                               |             |     |
| 4.80mm thickness Pad                        | PR5X-480-80 | 4   |
| 5.00mm thickness Pad                        | PR5X-500-80 | 4   |
| 4.90mm thickness Pad                        | PG5X-490-00 | 2   |
| Polishing Film                              |             |     |
| Adhesive Removal Film                       | GA5D        | 50  |
| Rough Polishing Film                        | DR5D        | 2   |
| Middle Polishing Film                       | DM5D        | 2   |
| Final Polishing Film                        | SF5D        | 50  |
| 0.05mm thickness Film<br>(for re-polishing) | 15303-05    | 2   |
| Other Accessories                           |             |     |
| Spare Coil Spring                           | FP-CS55     | 4   |
| Spare 2A Fuse                               | FP-F2A      | 10  |
| Allen Wrench Set                            | FP-TS       | 1   |
| Double-Sided Tape                           | FP-DST      | 1   |
| Power Cable                                 | FP-AC##     | 1   |
| Cable Holder                                | FP-CH       | 1   |
| Manuals                                     |             |     |
| Operating Manual                            | FP-IM55     | 1   |
| Polishing Process Manual                    | FP-PM55     | 1   |
| Maintenance Manual                          | FP-MM55     | 1   |

## § 2. Operating Procedures

## 2.1 Operating Panel

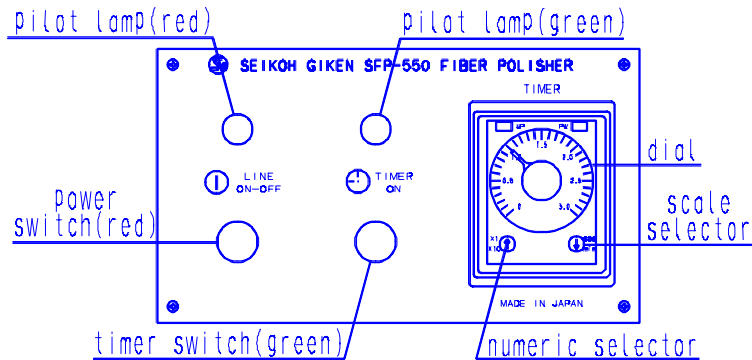
Front Panel

## &lt;Procedure&gt;

## ① Power Switch ON

Turn on the power switch. The red lamp will light up, and the cooling fan will start running.

## ② Timer Switch ON

Turn on the timer switch. The green lamp will light up, and the polishing machine (turntable) will be operating while the timer is running.

## ③ Timer Switch OFF

After the set time elapses, the polishing machine (turntable) will stop automatically and the green lamp will be off.

## ④ Power Switch OFF

Make sure you turn off the power switch when you stop or shut down the polishing machine. Check if all switch lamps are off.

This power switch alternates ON-OFF functions by pushing.

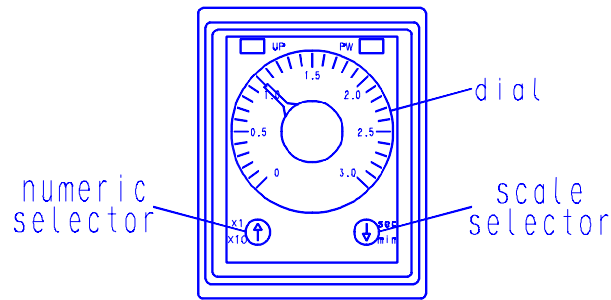
**Timer**

**Scale Selector:** Turning this screw one notch changes the scale indicated.

sec → min

\*Select [min] unless otherwise specified.

**Numeric Selector:** Turning this screw one notch changes the timing range as follows.

×1 → ×10

\*Select [×1] unless otherwise specified.

×1: Normal Time Setting

×10: Operates 10 times longer than the normal

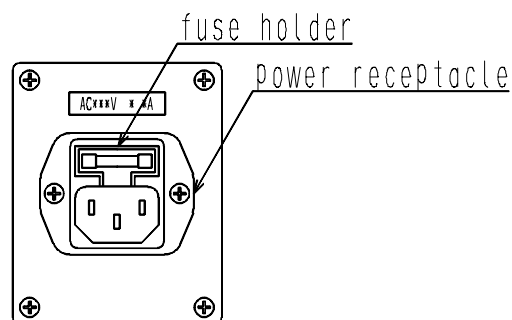
**Rear Panel**

**Fuse Holder:** To change the fuse, pull and remove it with fuse holder.

**Power Receptacle:** Insert the power plug into this receptacle.

## 2.2 Turntable Assembly

### Turntable Structure

The turntable structure is shown above. 6W motor & gearbox creates turntable rotation. 15W motor & gearbox also creates eccentric circular motion and turntable revolution.

### Turntable Maintenance

No maintenance is required on the turntable as a regular basis. However, inspection and cleaning are recommended every 3000~4000 hours of operation or every one or two years.

#### ~ ~ ~ Caution ~ ~ ~

- Please refer to the maintenance manual before you work on the maintenance.
- Please do not disassemble or apply any maintenance on the areas and parts not described on the maintenance manual.

## 2.3 Polishing Materials

### Polishing Film

Use the correct polishing film. Polishing films can be easily distinguished by color or label. Service life will vary depending on the type of film used. For more information, please refer to the Polishing Process Manual.

Service life also varies depending on its use and storage condition.

Store the polishing film in a dry environment after wiping the film dry and clean.

| Polishing Film | Identification         | Service Life |
|----------------|------------------------|--------------|
| <b>GA5D</b>    | <b>Green</b>           | <b>1</b>     |
| <b>DR5D</b>    | <b>Label (DR)</b>      | <b>15~20</b> |
| <b>DM5D</b>    | <b>Label (DM)</b>      | <b>15~20</b> |
| <b>SF5D</b>    | <b>Light Green</b>     | <b>1</b>     |
| <b>HF5D</b>    | <b>Semitransparent</b> | <b>1</b>     |
| <b>CF5D</b>    | <b>Light Brown</b>     | <b>50</b>    |

## Polishing Pad

Several polishing pad types are available for various uses. Use only the pad specified for each purpose. The identification mark of each pad is on the center of its reverse side. Attach a polishing film on top of the polishing pad as shown below. Replace the polishing pad with new one regularly as the lifetime of one year. Also replace it with new one when the pad is damaged or deformed.

### a. Pad for Convex Polishing

Made of synthetic rubber, this pad has an identification mark at the center of its reverse side. Make sure the top surface of the pad is clean when attaching a polishing film to it. Attach a polishing film to this pad with double-sided tape. Do not use thinner, acetone, or other solvents, since such solvents will affect the quality of the pad.

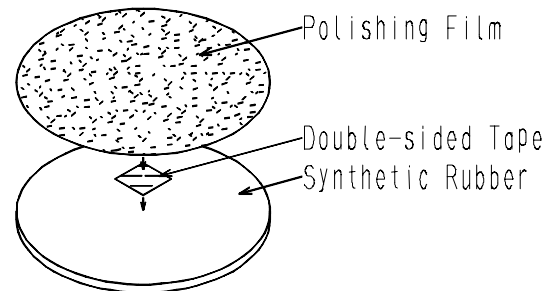

### b. Pad for Flat Polishing

Made of glass with antiskid rubber film on the reverse (bottom) side. This pad has an identification mark at the center of its reverse side. Make sure the top surface of the pad is clean when attaching a polishing film to it. Attach a polishing film to this pad with double-sided tape. Do not use thinner, acetone, or other solvents, since these solvents will affect the quality of the pad.

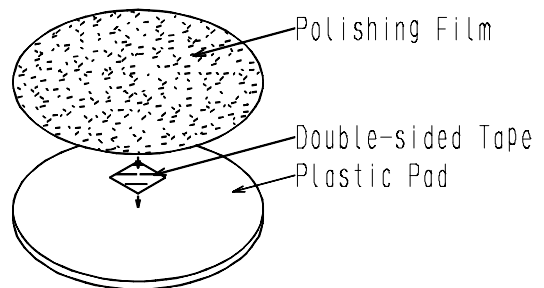

### **Important!**

**Apply the double-sided tape to the center diameter of 30mm on the pad so that the ferrule end faces, during polishing, will not be on the area that the double-sided tape be placed. When changing film, clean the surface of the pad and make sure the pad surface is free of foreign particles. Such particles can cause the film to come loose, or scratch the ferrule.**

## 2.4 Polishing Holder

### Polishing Holder Design

There are two types of polishing holders; one for right-angled flat or right-angled convex polishing and the other for angled flat or angled convex polishing. Each holder is available to suit different connector types.

The polishing holder has round shape cutouts on the four corners to place it onto the clamping posts of the base plate.

The polishing holders have 10, 12, 18 or 20 positions to install adapters as shown in the right hand figure. After the adhesive removal process, the tip of ferrules must protrude 0.5mm from the bottom side of the polishing holder. The protrusion is critical to the accuracy of the polishing process.

☆☆☆ **CAUTION** ☆☆☆

Make sure that the ferrule-reference plane and the ferrule insertion hole are clean. This will ensure that all ferrules protrude to the same height, thereby ensure desired polishing results.

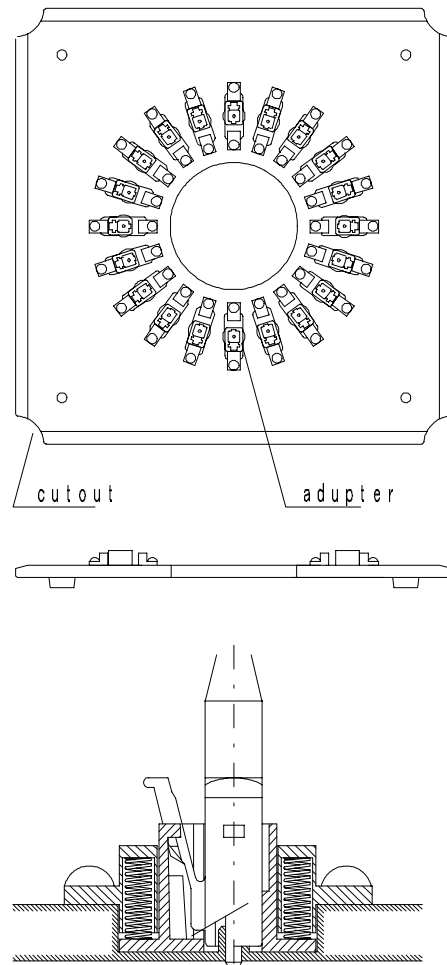

### Maintenance Requirement

Accuracy of polishing holders affects on polishing result. Thus, please be aware with these points.

- Before installing ferrules, please make sure to clean ferrules and ferrule insertion holes with lint-free tissues.
- The polishing holders are made of stainless steel. However, to avoid its rusting, it is recommended that all traces of water must be removed and lubrication oil is sprayed after use. Although the polishing holders are heat-treated, please avoid anything leads to damage such as bending, falling, or applying any shock.

## 2.5 Pressurizing & Holding Unit

The clamping posts standing on the four corners of the base plate have pressurizing units with coil springs inside. The clamps on the corners hold the polishing holder.

The height of the clamping posts is set to provide 0.1mm impression of the ferrules into the polishing film by the manufacturer. The clamping posts should only be disassembled if it becomes necessary to adjust this setting.

Adjustment for the height of the clamping posts is required when the protrusion of the ferrule tips is not 0.5mm from the bottom side of the polishing holder, because of changing ferrules.

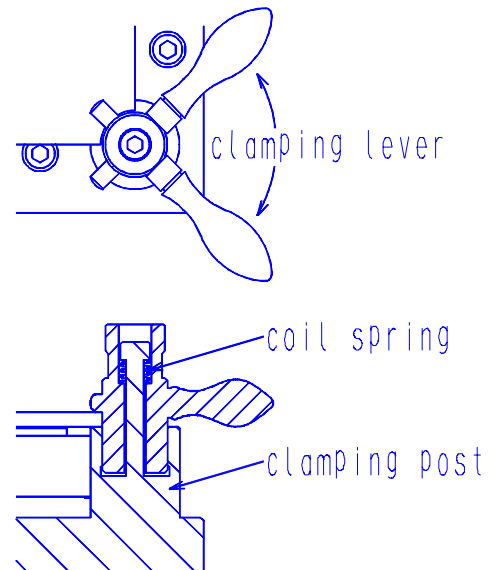

- Please refer to the maintenance manual in case of adjusting the height of the clamping posts and replacing coil springs.

### Operation

- ① Mount optical connectors or ferrules on the polishing holder.
- ② Install the polishing holder on the polishing machine.
  - Turn the clamping levers on the four corners so that their pressure pins are clear off the polishing holder area.
  - Place the polishing holder on the polishing machine between the clamps.
  - Pull up and turn the four clamping levers until their pressure pins are fully over the polishing holder.
  - Turn the four clamping levers when the holder is removed.

