

High Precision Variable Fiber Optical Attenuator (High Setting Precision, Low Loss, Broad Band, Latching)

(US patent 8,666,218 and other patents pending)

Product Description

The High Precision Series VOA is based on a micro-electro-mechanical system (MEMS) device platform driven by a mini-motor integrated with an optical position sensor. It uniquely offers advantageous performances that are unmatched in the industry. It features ultra-broadband from 200 to 2500nm, ultra-low insertion loss of less than 0.2dB, ultra-high setting precision, high optical power handling, and latching function. Once, the VOA attenuation value is set, it will latch to and remain at the value regardless of the environment variations and the loss of electrical power. It is available with all types of fibers having a 125 micron outer diameter.

The VOA is driven by a attached PCB having USB or RS232 computer interfaces with GUI software. A USB connection will provide sufficient power for the device. A wall-mount 12V DC supply is provided for RS232 function

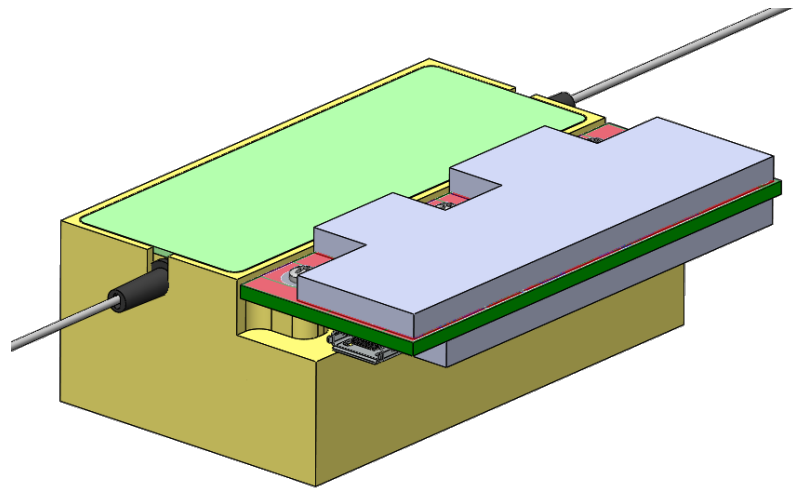

Performance Specifications

Precision Motor Series VOA	Min	Typical	Max	Unit
Operation Wavelength	300		2500	nm
Insertion Loss ^[1]		0.2	0.5	dB
Polarization Dependent Loss		0.15	0.5	dB
Wavelength Dependence Loss		0.1	0.2	dB
Attenuation Range		50	60	dB
Attenuation Setting Repeatability			0.1	dB
Attenuation Setting backlash			0.2	dB
Extinction Ratio (PM version only)	18	23	25	dB
Polarization Mode Dispersion (SM version only)		0.01	0.05	ps
Return Loss	45			dB
Response Time			100	ms
Optical Power handling		600	800	mW
Operating Temperature	-5		75	°C
Storage Temperature	-40		85	°C
Package		40x25x10		mm

Notes:

- [1]. Without connector and at room temperature
- [2]. At attenuation equal or less than 20 dB
- [3]. At 0dB attenuation and at whole temperature range
- [4]. Within 40nm Bandwidth
- [5]. At 20dB attenuation for transparent version, at 0.8dB attenuation for opaque version.
- [6]. This is related to tap ratio. The spec data is regarding 3% tap.

Features

- Very Low Loss
- Highly Repeatable
- Latching
- High Resolution
- Large Attenuation

Applications

- Power Control
- Power Regulation
- Channel Balance
- Instrumentation



Electrical Control Interface



The VOA can be controlled via USB and RS232 interfaces

USB - Using a Micro-USB cable connects to a computer's USB port. This connection does not need for extra power supply. The device accept UART command and recognized as a serial device by the PC.

RS232 – Using a special cable connect to a computer's RS232 port. An extra 5-12V power supply by Agiltron needs to connect to the VOA via a connector on the board.

Mechanical Footprint Dimensions (Unit:mm)

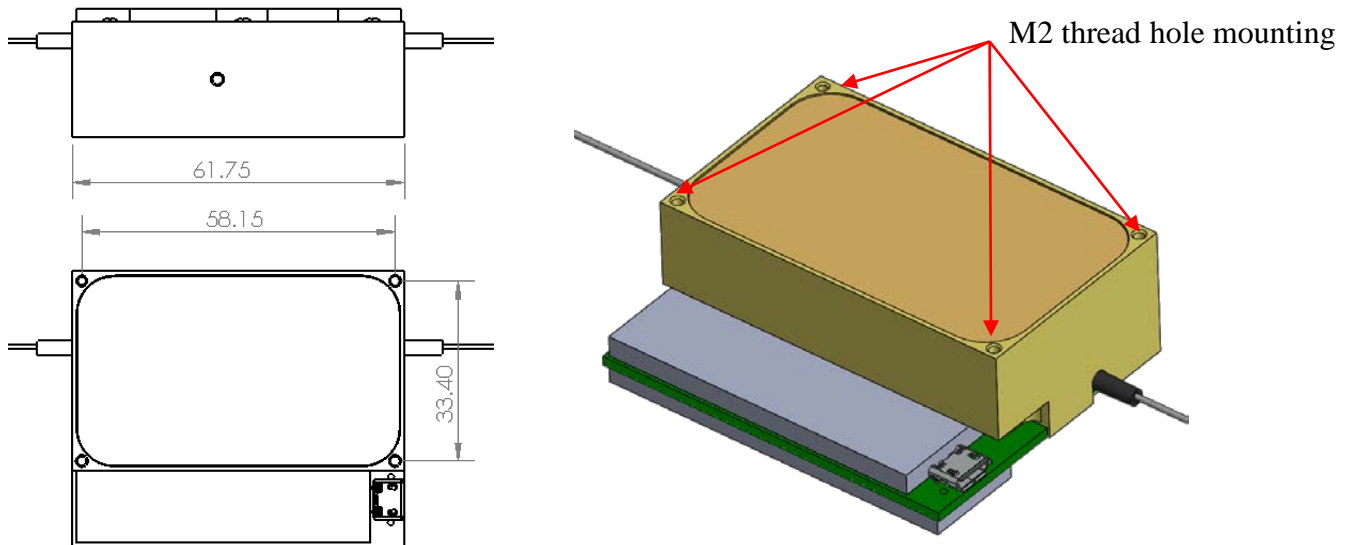

Ordering Information

FFOA-	<input type="checkbox"/>	<input type="checkbox"/>	<input type="checkbox"/>	<input type="checkbox"/>	<input type="checkbox"/>	<input type="checkbox"/>	<input type="checkbox"/>	<input type="checkbox"/>
	Type	Controller	Off State	Test Wavelength	Fiber type	Fiber Length	Connector	
	Moto=5 Special=00	No =0 USB/I2C=1 RS232/SPI=2	Transparent =1 Special =0	488 = 4 532 = 5 630 = 6 780 = 7 850 = 8 980 = 9 1060 = 1 1310 = 3 1550 = C 2000 = 2 Special = 0	Pick from below table	Bare fiber=1 900um tube=3 Special=0	0.25m=1 0.5m=2 1.0m=3 Special=0	None=1 FC/PC=2 FC/APC=3 SC/PC=4 SC/APC=5 ST/PC=6 LC=7 Special=0

01	SMF-28	34	PM1550	67	OM1 (MMF 62.5/125um)
02	SMF-28e	35	PM1950	68	OM2 (MMF 50/125um)
03	Corning XB	36	PM1310	69	OM3 (MMF 50/125um)
04	SM450	37	PM400	70	OM4 (MMF 50/125um)
05	SM2000	38	PM480	71	GIF50 (GIF 50/125um)
06	SM600	39	PM630	72	GIF625 (GIF 62.5/125um)
07	Hi780	40	PM850	73	106/125um
08	SM800	41	PM980	74	FG105LCA
09	Hi980	42		75	FG50LGA
10	Hi1060	43		76	
11	Draka BBE	44		77	
12	Draka BBE	45		78	

Tel: (781) 935-1200 Fax: (781) 935-2040