

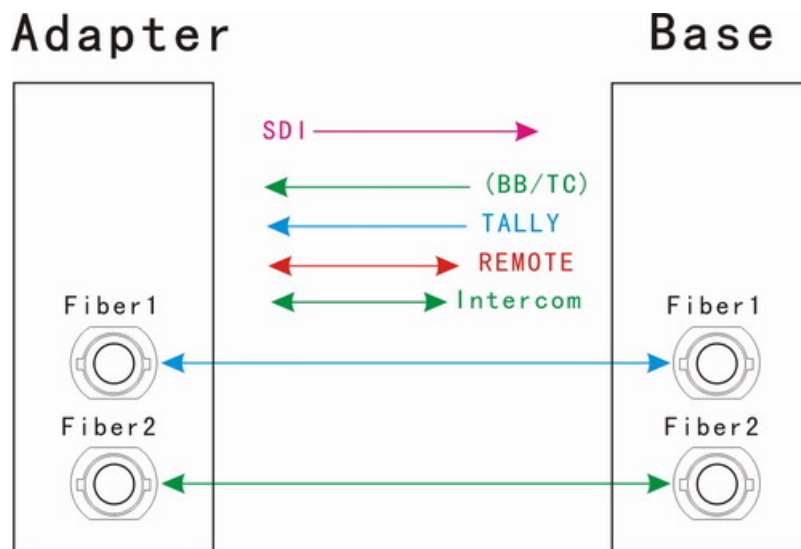

4 ch EFP to Fiber for SONY HDW-750

Description:

BY-EFP-405 includes 4 Camera Optic Adaptors and 1 Optic Base Station(4 channel). The system transports a 3G/HD-SDI signal from the Sony HDW-730 or HDW-750 series camera to the Base Station, Reverse video(SDI or CVBS), Remote control data(SONY's 8 pin interface, Connect Sony RCU/RCP RM-B150, RM-B170, RM-B750), Intercom (Camera end can be connected professional 4-pin or 5-pin XLR headset, OB end can be connected Clearcom or RTS , etc intercom main station), Tally(1 or 2 colors is optional). Genlock signal, blackburst/trilevel sync or Time code is optional. The system puts all of the signals needed for multi-camera 3G/HD-SDI production on a SM / MM tactical or SMPTE hybrid fiber cable, insuring robust, trouble-free connectivity on any studio or remote production.



Application:

- Television Broadcast(studio):
 - Sports
 - News
 - SNG
 - Trackside
- Links Between in-field and OB van(outside broadcast truck)

Features:

- Handle all Pathological patterns
- Automatic cable equalization to ensure signal integrity
- 3G/HD/SD-SDI input auto recognition, support 270Mbit/s - 2.97Gbit/s according to SMPTE 424M, SMPTE 292M and SMPTE 259M
- 10+Km on single mode fiber or 300m on multimode fiber transmission
- Mic inputs with mute and pre-amps ,with amplifier for phones
- Remote control for SONY's or Panasonic's camera
- V-mount or A-mount battery plate is optional

Specifications:**General index:**

Work Temp	-25°C to 55°C
Storage Temp	-40°C to 85°C
humidity	0 ~ 95% (non-condensing)
Camera Optic Adaptor	
Input power	DC 11~19V
Power consumption	<8W
Net weight	1kg
Appearance size	188mm*116mm*45mm(without V-mount / A-mount)
Optic Base Station	
Input power	AC90~240V
Power consumption	<20W
Net weight	3kg
Appearance size	19" 1U standard rack mount

Optical:

Wavelength	1310nm / 1550nm / CWDM
Output Power	-6~-1dBm
Rx sensitivity	<-18dBm
Transmission Distance	SM fiber 10+km , MM fiber 300m
Optical connector	Du LC /FC/ST/SC/ Lemo 3K.93C/ Neutrik OpticalCON DUO

SDI input/output:

Signal format	SMPTE 424M, SMPTE 292M, SMPTE 259M
Data rate	270Mbit/s - 1.48Gbit/s - 3Gbit/s
Cable Equalization	Automatic cable EQ (Belden 1694A cable) 250m @ 270Mbit/s, 140m @ 1.5Gbit/s, 80m @ 3Gbit/s
SDI interface	BNC 75 Ohm

Intercom:

Camera Optic Adaptor	
Interface	4pin XLR(Male) /5pin XLR(Female)
Microphone	Mic inputs with mute and pre-amps
Headphone	With amplifier and volume up or down

Optic Base Station	
Interface	3pin XLR Female/Male: Party line audio for Clearcom or RTS Intercom main station DB9(Male): Line level audio input and output

Tally:

Camera Optic Adaptor	
Interface	4pin air head or 3pin mini XLR
Output	Dry Contact Closure or wet LED+/- On: short or LED on Off: open or LED off
Optic Base Station	
Interface	DB9(Male)
Input	Dry Contact Closure or TTL On: short to GND or TTL low Off: open or TTL high

Remote:

Camera Optic Adaptor	
Interface	SONY's 8 pin or Panasonic's 10 pin interface
Data	RS422 /RS232/RS485
Optic Base Station	
Interface	SONY's 8 pin or Panasonic's 10 pin interface
Data	RS422 /RS232/RS485

Panel diagram (satellite+base):

