

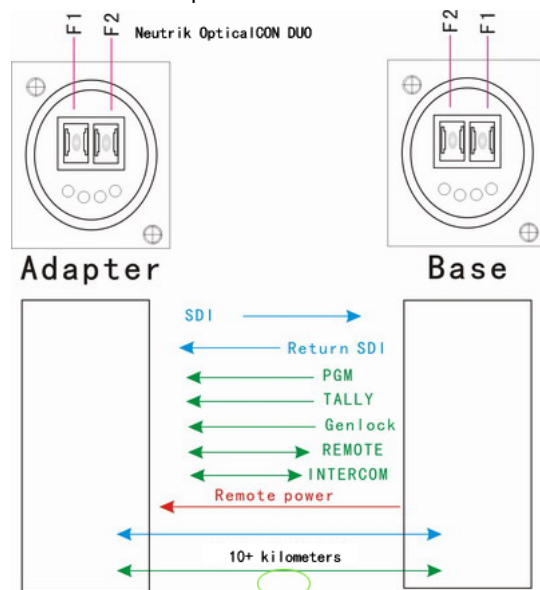

## EFP To Fiber for JVC

### Description:

**BY-EFP-418 for JVC** includes a Camera Optic Adaptor and a Optic Base Station. The system transports 1 ch 3G/HD-SDI signal from the JVC camera to the Base Station, 1 ch Reverse 3G/HD-SDI, PGM, Genlock or TC/BB, Remote control(Connect a Remote Control Unit RM-LP55/RM-LP57), intercom (Camera end can be connected professional 4-pin or 5-pin XLR headset, OB end can be connected intercom main station), tally(One color or two colors can be selected), Remote camera power supply (15V DC up to 150 Watts). The system puts all of the signals needed for multi-camera 3G/HD-SDI production on a SM tactical or SMPTE hybrid cable, insuring robust, trouble-free connectivity on any studio or remote production.



### Application:

1. Television Broadcast(studio):
  - Sports
  - News
  - SNG
  - Trackside
2. Links Between in-field and OB van(outside broadcast truck)

**Features:**

- 1 ch forward and 1 ch reverse SDI
- Handle all Pathological patterns
- Automatic cable equalization to ensure signal integrity
- 3G/HD/SD-SDI input auto recognition, support 270Mbit/s - 2.97Gbit/s according to SMPTE 424M, SMPTE 292M and SMPTE 259M
- 10+Km on single mode fiber transmission
- Mic inputs with mute and pre-amps
- Headphone with PGM / Intercom volume up or down
- Remote control (Connect a Remote Control Unit RM-LP55/RM-LP57)
- Tally LED+/- output or dry Contact Closure optional
- V-mount or A-mount battery plate optional, Upper battery plate can be changed to heat sink
- Genlock or TC/BB are also available
- Remote camera power supply (15V DC up to 150 Watts), with insertion detection protection

**Specifications:****General index:**

Work Temp	-25°C to 55°C
Storage Temp	-40°C to 85°C
humidity	0 ~ 95% (non-condensing)
Camera Optic Adaptor	
Input power	DC 11~19V
Power consumption	<12W
Net weight	1kg
Appearance size	188mm*116mm*45mm (without V-mount / A-mount)
Optic Base Station	
Input power	AC90~240V
Power consumption	<12W
Net weight	3kg
Appearance size	19" 1U standard rack mount

**Optical:**

Wavelength	1310nm / 1550nm / CWDM
Output Power	-6~-1dBm
Rx sensitivity	<-18dBm
Transmission Distance	Remote power 150W, SMPTE hybrid cable 200+m
Optical connector	Lemo SMPTE 304 / Neutrik OpticalCON DUO Camera end can be rotated 90 degrees

**SDI input/output:**

Signal format	SMPTE 424M, SMPTE 292M, SMPTE 259M
Data rate	270Mbit/s - 1.48Gbit/s - 3Gbit/s
Cable Equalization	Automatic cable EQ (Belden 1694A cable) 250m @ 270Mbit/s, 140m @ 1.5Gbit/s, 80m @ 3Gbit/s
SDI interface	BNC 75 Ohm

**Genlock / TC / BB**

Number of Channels	1
Input/output impedance	BNC 75Ω (unbalance)
Input/output voltage	1.0Vp-p
Differential Gain	< ±1.5%
Differential Phase	< ±1%
SNR	>60dB

**Intercom:**

Camera Optic Adaptor	
Interface	4pin XLR(Male) /5pin XLR(Female)/ 3.5mm headset jack
Microphone	Mic inputs with mute and pre-amps
Headphone	with volume up or down
Optic Base Station	
Interface	3pin XLR Female/Male: Party line audio for Clearcom and RTS Intercom main station ,or Line level balanced audio input and output DB9(Male): Line level unbalanced audio input and output,

**PGM:**

Camera Optic Adaptor	
Interface	4pin XLR(Male) /5pin XLR(Female)/ 3.5mm headset jack
Headphone	with volume up or down
Optic Base Station	
Interface	3pin XLR Female: Line level balanced audio input

**Tally:**

Camera Optic Adaptor	
Interface	4pin air head or 3pin mini XLR
Output	Dry Contact Closure or wet LED+/-
	On: short or LED on Off: open or LED off
Optic Base Station	
Interface	DB9(Male)
Input	Dry Contact Closure or TTL
	On: short to GND or TTL low Off: open or TTL high

**Remote:**

Camera Optic Adaptor	
Interface	JVC Round 6-pin
Data	JVC Remote Control data
Optic Base Station	
Interface	JVC Round 6-pin
Data	JVC Remote Control data

Panel diagram(Satellite+ Base):

