

AI-9 **PRODUCT MANUAL**



OPTICAL FIBER FUSION SPLICER



NEW PRODUCT LAUNCH

CLASSIC MASTERPIECE

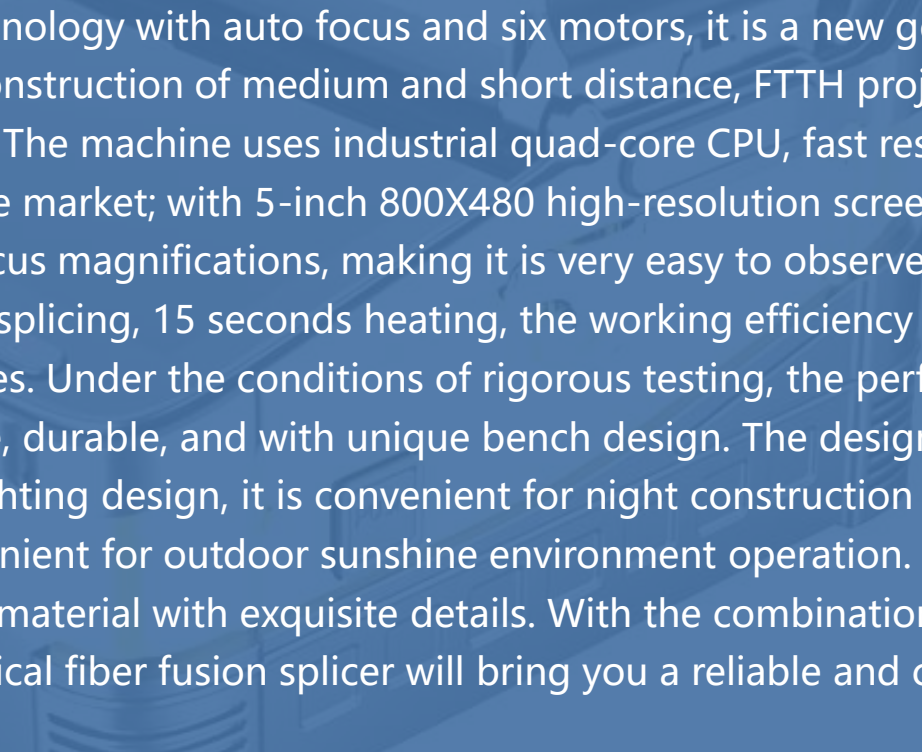

AI-9 use the latest core alignment technology with auto focus and six motors, it is a new generation of fiber fusion splicer. It is fully qualified with trunk construction of medium and short distance, FTTH project, security monitoring and other fiber cable splicing projects. The machine uses industrial quad-core CPU, fast response, is currently one of the fastest fiber splicing machine in the market; with 5-inch 800X480 high-resolution screen, the operation is simple and intuitively; and up to 300 times focus magnifications, making it is very easy to observe the fiber with naked eyes. 5 seconds speed core alignment splicing, 15 seconds heating, the working efficiency increased by 50% compared to ordinary splicing machines. Under the conditions of rigorous testing, the performance is still outstanding; toolbox is small, exquisite, durable, and with unique bench design. The design of operating platform reflects the humanistic care; unique lighting design, it is convenient for night construction or repair. Screen brightness is adjustable and it is convenient for outdoor sunshine environment operation. The core parts are using imported brands, aviation metal body material with exquisite details. With the combination of advanced technology and design, the new generation of optical fiber fusion splicer will bring you a reliable and comfortable user experience.

MASTERPIECE HIGH-END LUXURY

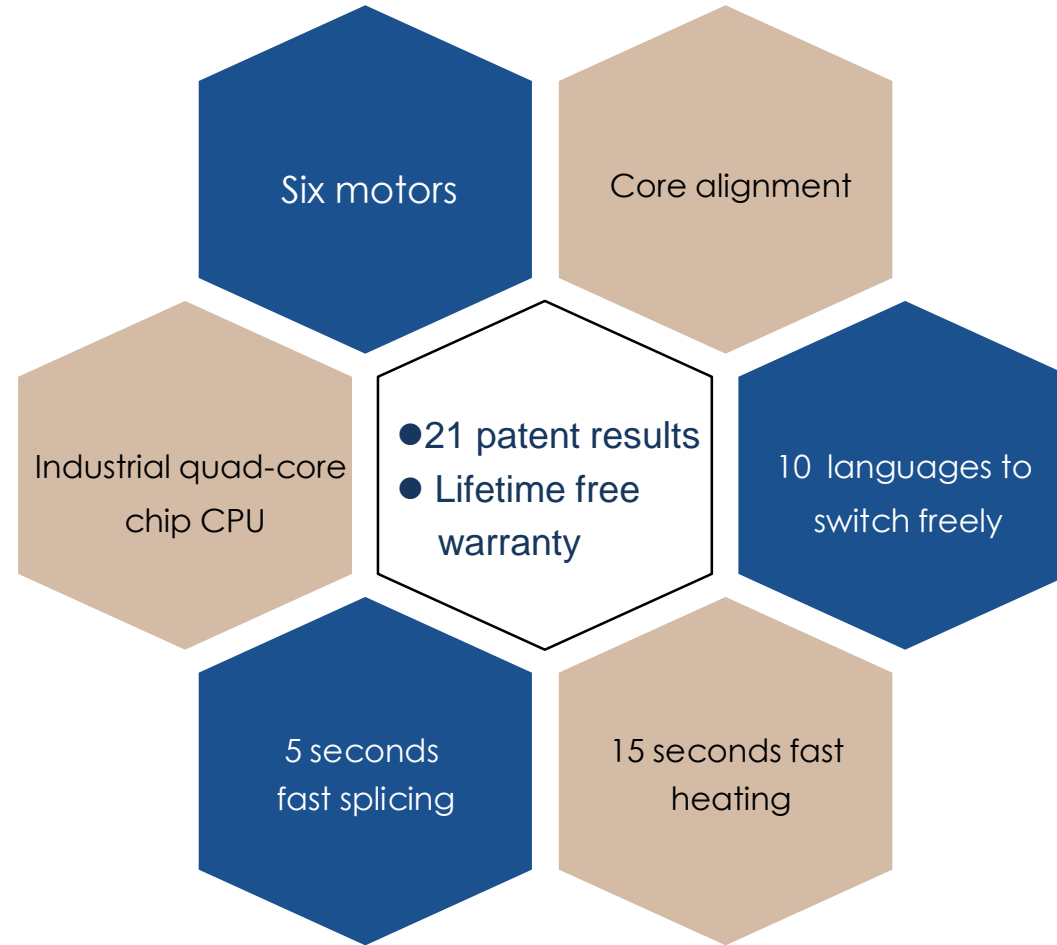

- Once splicing reaches to 50,000 times free replacement a new machine

METAL BODY

AESTHETIC DETAILS

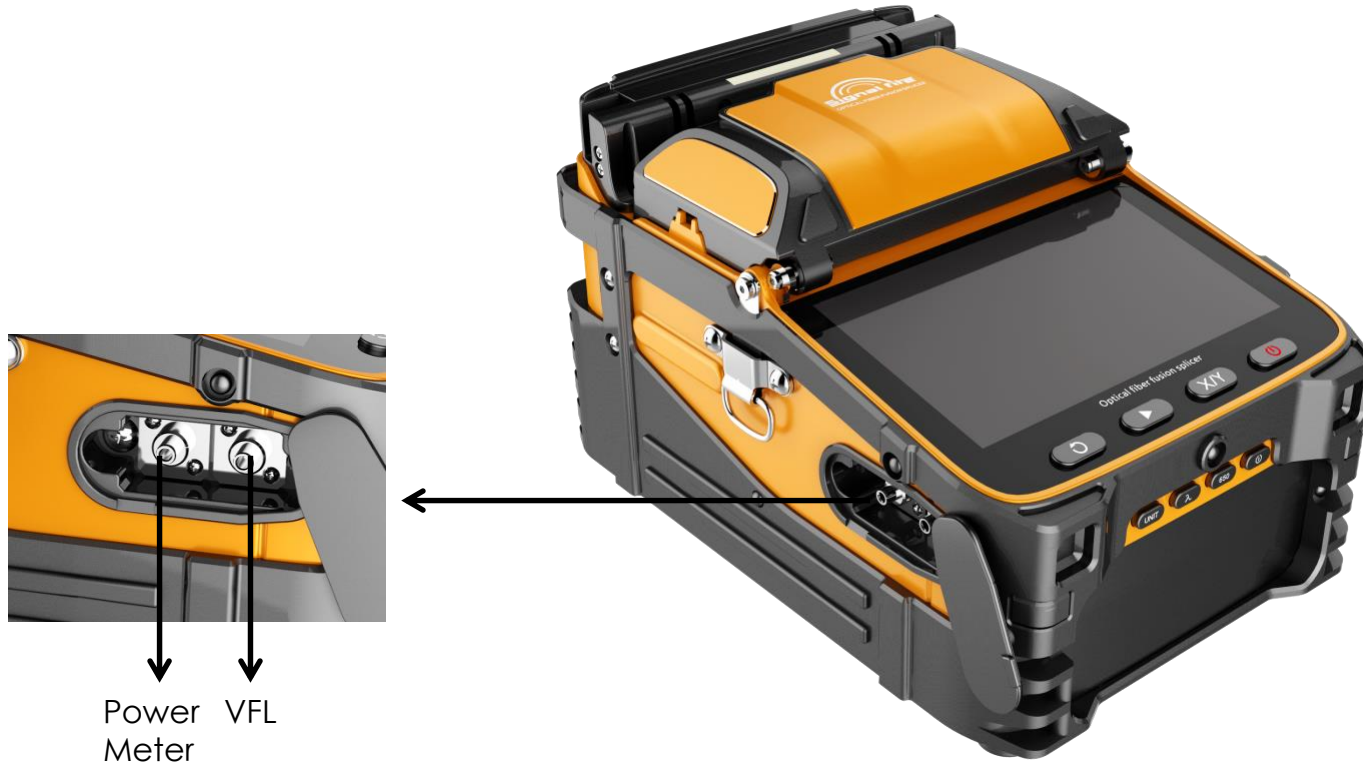

VFL: Always on / flashing / off

Power Meter:

850nm/1300nm/1310nm/1490nm

/1550nm/1625nm Six states

BUILT-IN POWER METER AND VFL

Effectively measure connection loss, verify continuity, and help assess fiber link transmission quality.

10 LANGUAGES TO SWITCH FREELY

Covers the global major user market

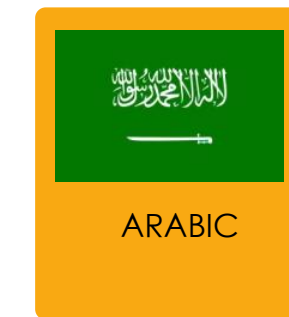
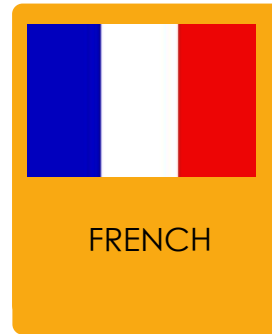

CORE PARTS QUALITY ASSURANCE

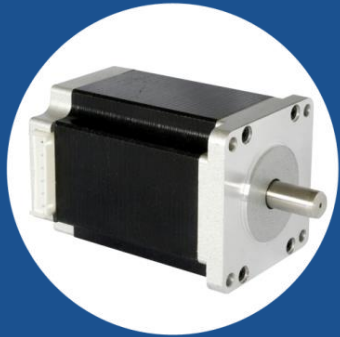

Siemens stepper motor



Roth ROUST linear guide



Sanyo lithium battery



Aviation metal material

THE TOOLBOX

COMES WITH A STOOL TO FACILITATE THE CONSTRUCTION WORKERS.



Remove the stool



Do not need to take out the splicer machine from the toolbox while working.

Fiber cleave operator station

Two layers



Stool can bear

100kg

INDUSTRIAL QUAD-CORE CHIP CPU



**Synchronous
operation**

**speed
response**

**no
jammed**

**super
experience**

3 IN 1 FIBER HOLDER

SM, MM, bare fiber, pigtail, rubber-insulated, multi fiber cable

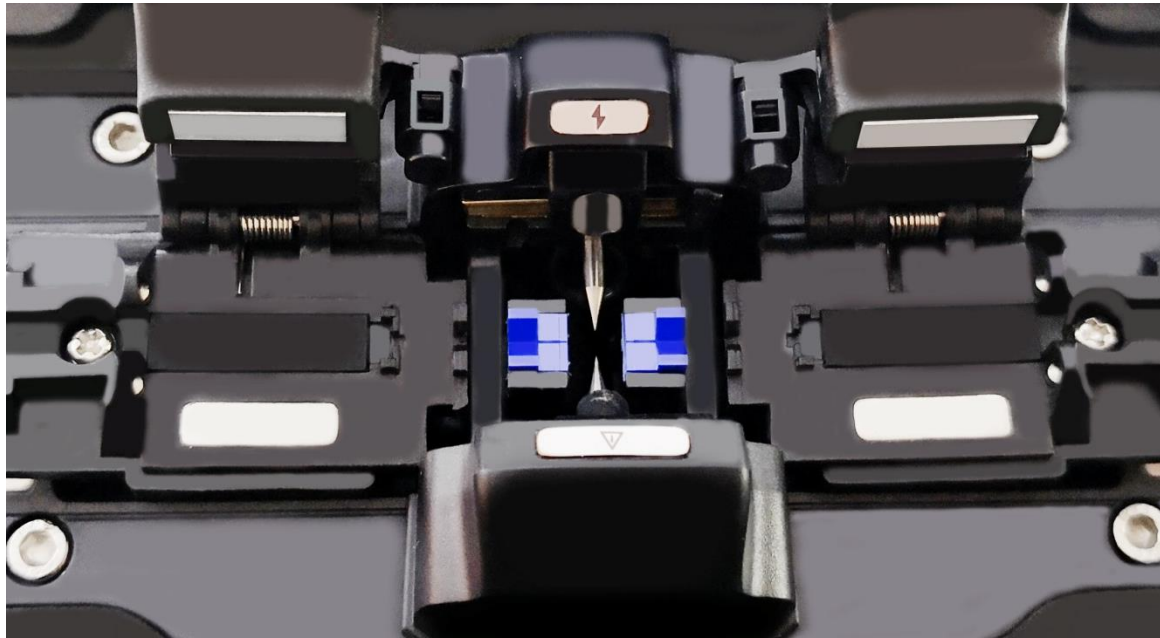

THE BATTERY POPUP AUTOMATICALLY



7800 mA high-capacity lithium battery

- charging time \leq 3.5 hours
- continuous splicing and heating
about 200 times



Press to popup
the battery

Show good performance in plateau,
desert, and extreme cold environment



BASIC PARAMETER

Fiber alignment	Core/cladding alignment / Manual alignment	Built-in lighting	easy for night operation
Splicing time	5S	Tension Test	Standard 2N
Heating time	15S	Fiber holders	3 in 1 fiber holder, SM, MM, bare fiber, pigtail, rubber-insulated, multi fiber cable
Heating mode	Automatic heating (Preheating)	Magnification	300 for X or Y view, 150 for X or Y view
Focus mode	Six motors Auto focus	Screen	5 inch TFT color display
Applicable Fibers	SM(G.652&G.657)、MM (G.651) 、DS(G.657)、NZDS (G.655)	Splicing Mode	Normal / high precision splicing
Splice Loss	0.025dB (SM) 、 0.01dB (MM) 0.04dB (DS/NZDS)	Splicing method	Fully automatic、 Step by step splicing
Control technology	Real-time control and calibration of fusion ARC	Splicing record storage	Synchronize to the phone, the server to cloud storage unlimited
Return loss	Better than 60DB	Built-in battery	7800 mA high-capacity lithium battery, charging time ≤ 3.5 hours, continuous splicing and heating about 200 times
Fiber diameter	Cladding Diameter: 80-150μm Coating Diameter: 100-1000μm	Power supply	Input AC100-240V 50 / 60HZ, output DC13.5V / 4A, the current power mode can be identified, real-time detection of battery power
Fiber Cleave Length	Coating less than 250μm: 8-16mm Coating less than 250-1000μm:16mm	Operating Conditions	Temperature -15 ~ +50 °C, humidity: <95% RH (no condensation) Working altitude: 0 ~ 5000m. Resist max. wind speed: ≤ 15m / s
Software updates Length	Automatically update、 Update by a key	Shrinkable tube	60mm、 50mm、 40mm、 25mm
Boot time	1 second	Product protection	Waterproof, dust proof, shock-resistant
Visual Fault Locator	Power:15mw,2hzflashing And Constantly Bright Mode	Optical Power Meter	Wavelength:850nm、 1300nm、 1310nm、 1490nm、 1550nm、 1625nm Measuring Range:-70 ~ +6db Absolute Error:<0.3db(-50dbm ~ +3dbm Range)

Accessories in the tool box



Fiber Cleaver



Spare electrode



Wire stripping pliers



Miller stripper

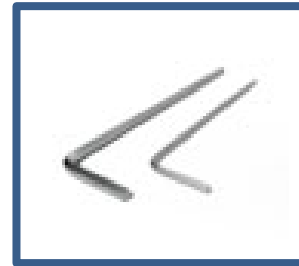

Hex key



carrying case

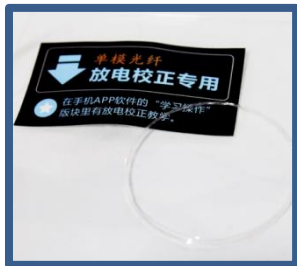

Fiber for
ARC calibration



Strap



Power Adapter



Alcohol Bottle



Brush



User's manual
Quality Certificate
Warranty Card

SIZE

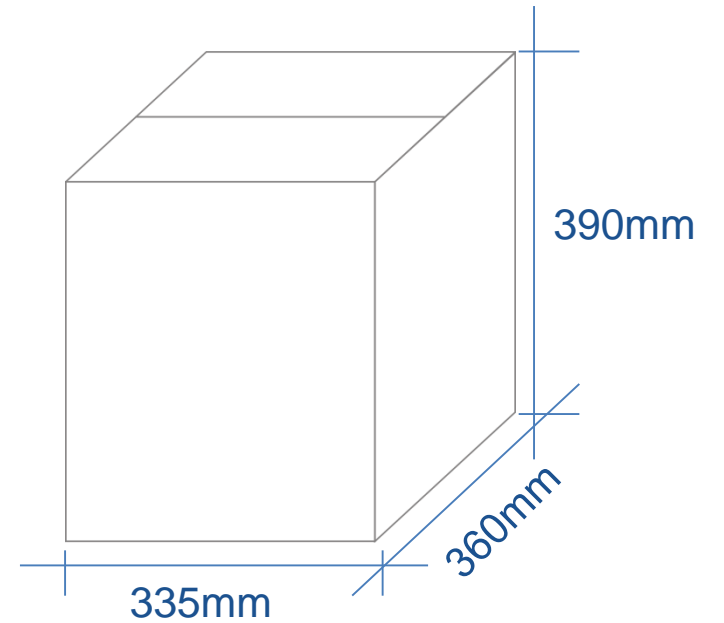
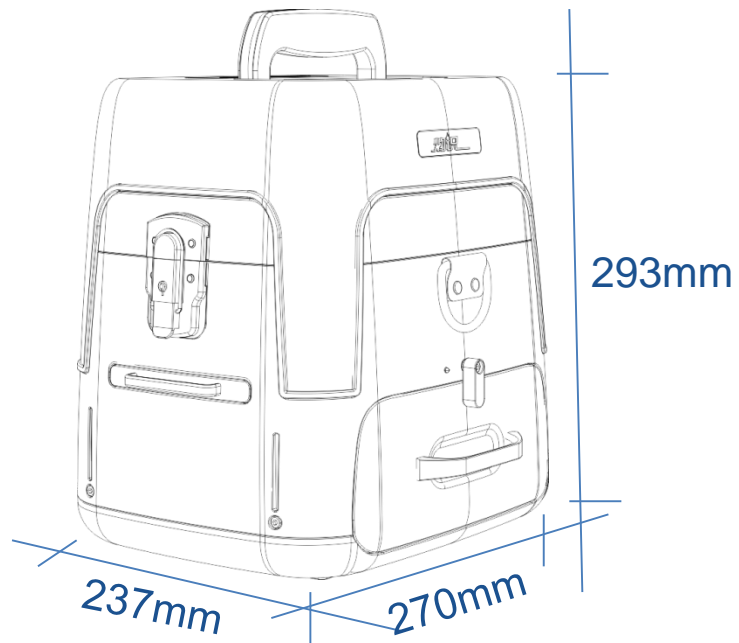
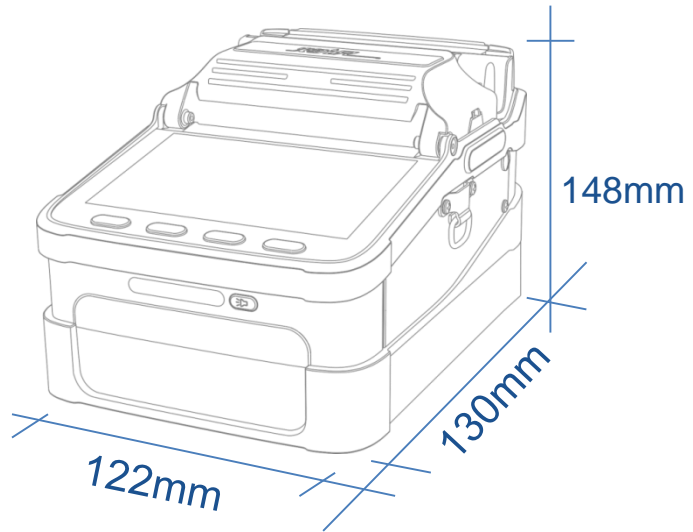

EXHIBITION PHOTOS

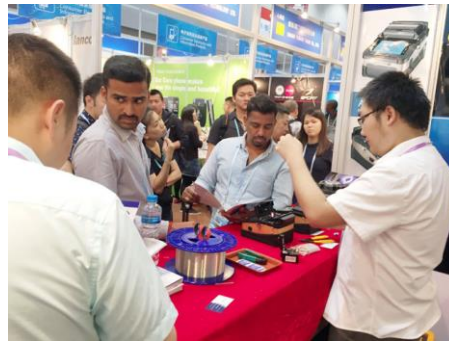
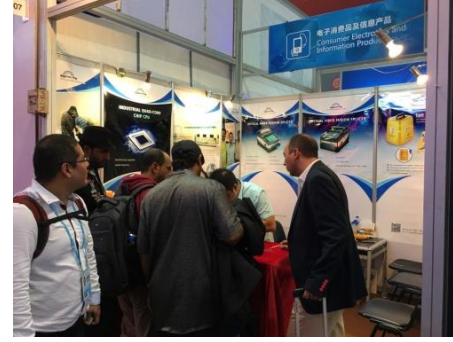

INTELLECTUAL PROPERTY



CE

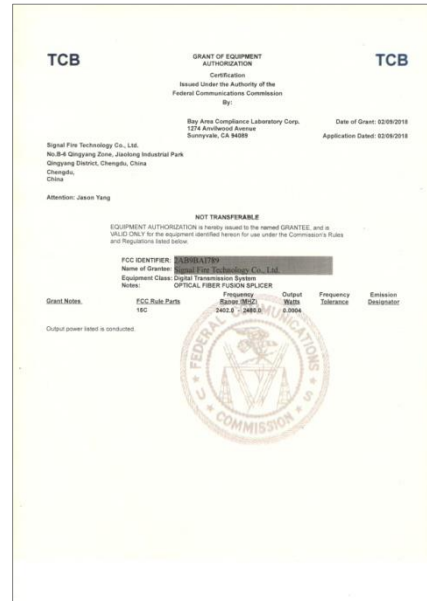

FCC

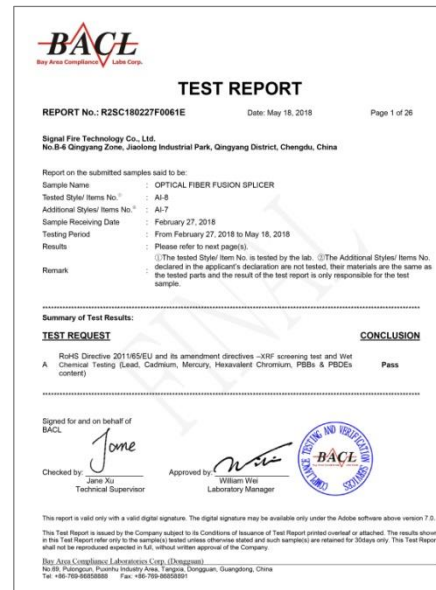

ROHS



IOS9001

PATENTS FOR INVENTIONS

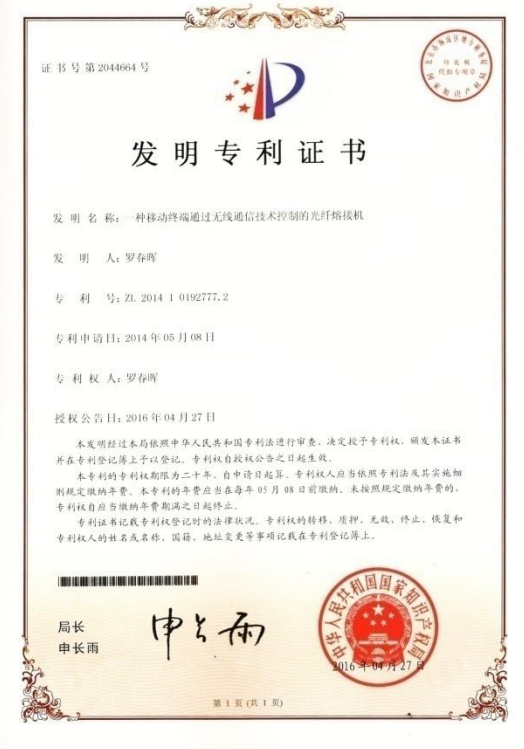
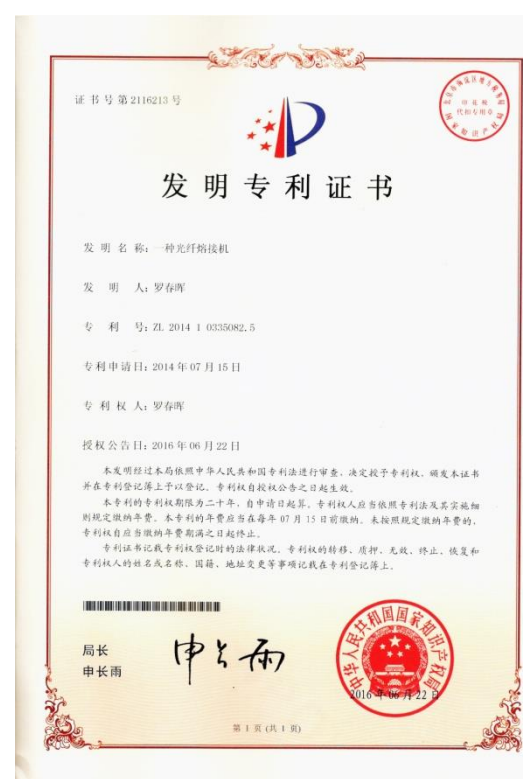
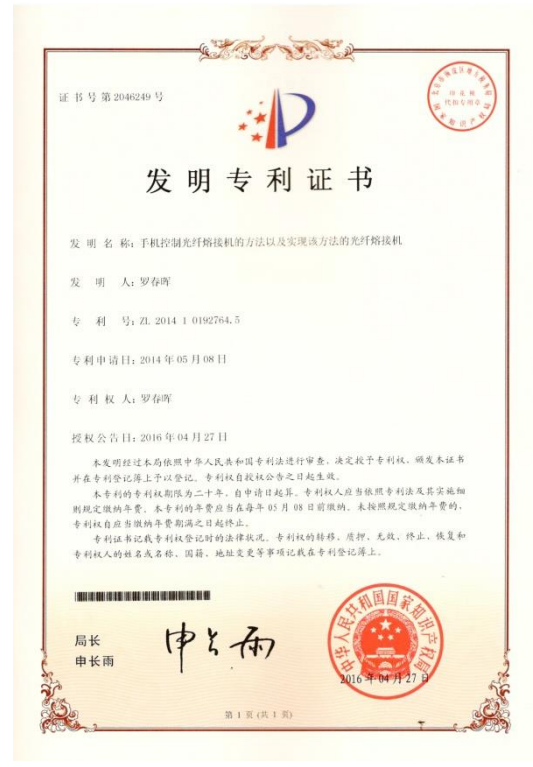
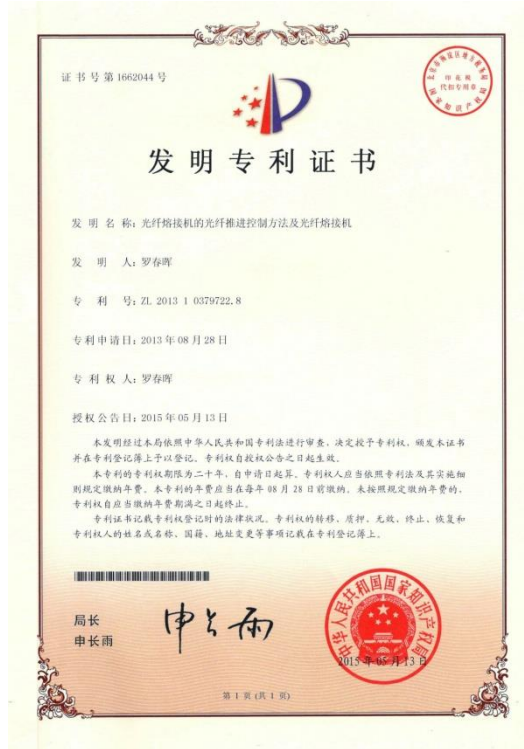

PATENTS OF UTILITY MODEL

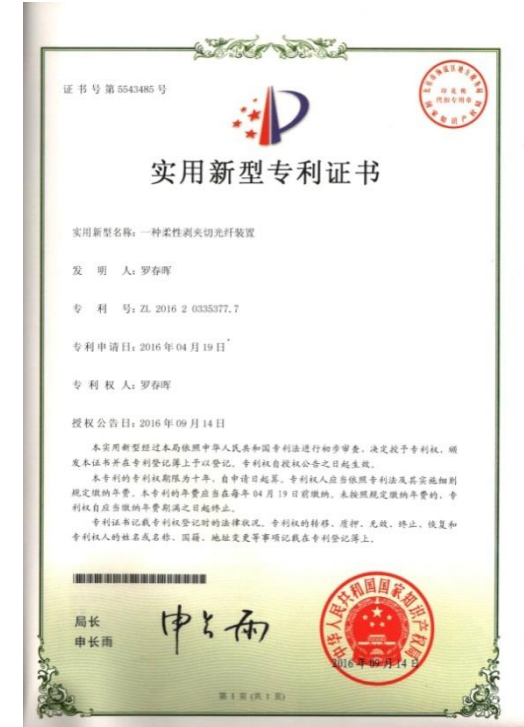
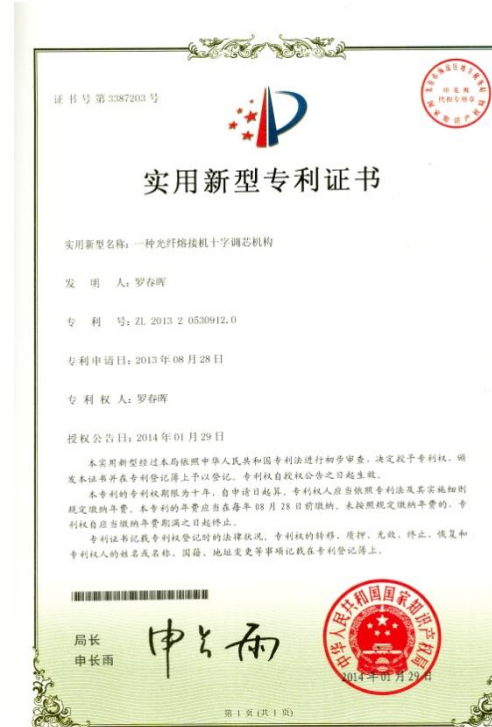
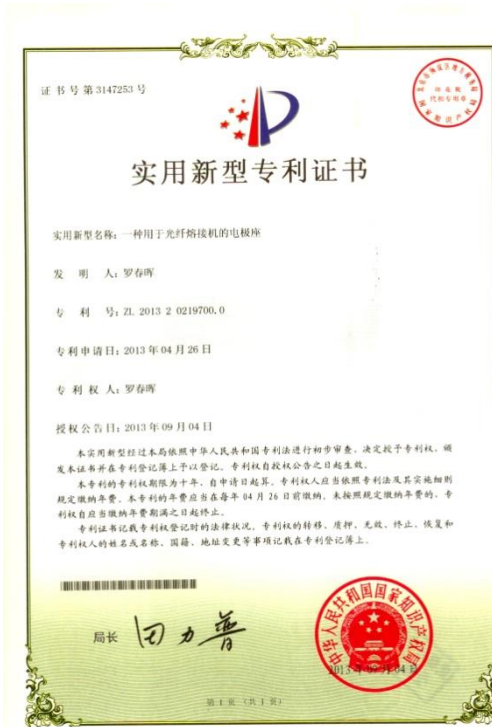
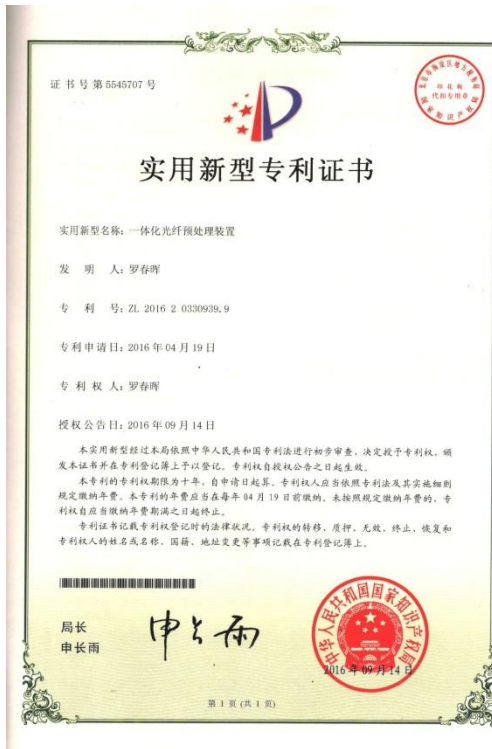

PATENTS OF UTILITY MODEL

