

Features

- SMPTE 297-2006 compatible
- Robust error-free transmission of signals from 50Mbps to 3Gbps with up to 40km single-mode fiber
- Maximum distance of 40km under worst-case conditions and 3Gbps video pathological signals
- Supports video pathological patterns for SD-SDI,HD-SDI and 3G-SDI
- SFP Package.Hot-pluggable
- Metal enclosure for lower EMI
- +3.3V single power supply.
- Two independent laser disable pins
- Digital diagnostics and control via I²C interface, including:
 - Monitoring laser bias current, average output power, supply voltage and temperature
 - Alarm reporting when transmitter is at fault
 - Module ID polling
- Compliant ROHS and lead free

Applications

- SMPTE 297-2006 compatible electrical-to-optical interfaces

Descriptions

The 2TPXXYYD6-11-SDI is a dual channel optical CWDM transmitter module designed to transmit optical serial digital signals as defined in SMPTE 297-2006. The 2TPXXYYD6-11-SDI is specifically designed for robust performance in the presence of SDI pathological patterns for SMPTE 259M, SMPTE 344M, SMPTE 292M and SMPTE 424M serial rates.

Ordering Information

2TPXX YYD6-11-SDI



Functional Block Diagram

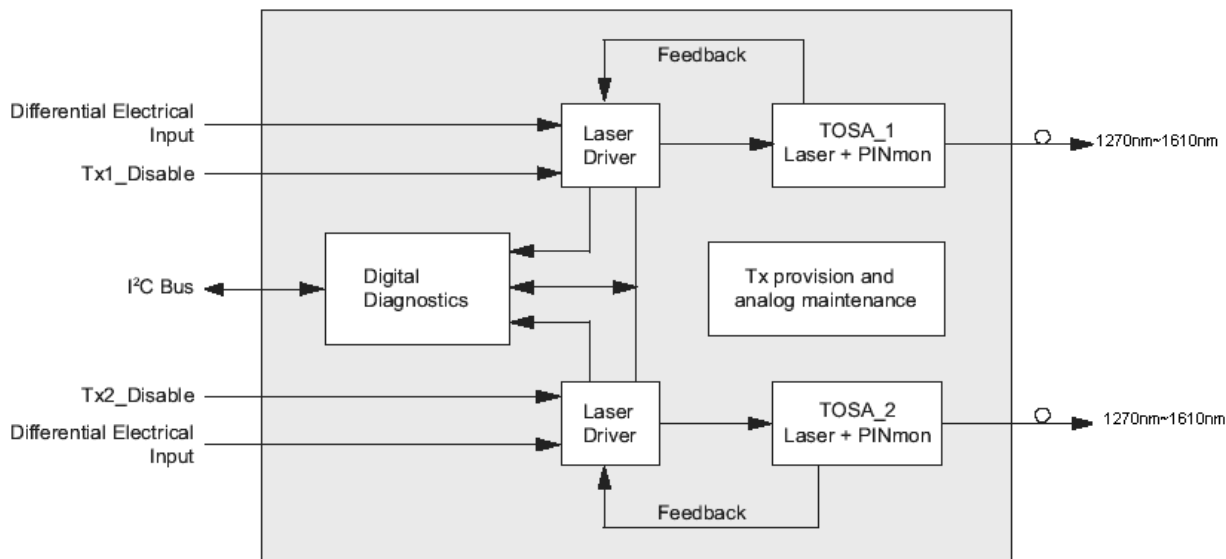

Figure 1: 2TPXXYYD6-11-SDI Functional Block Diagram

Pin Description

Pin Out Diagram

20 TX1-DIS	1 VEE
19 TD1-	2 NC
18 TD1+	3 NC
17 VEE	4 VEE
16 VCC	5 SCL
15 VCC	6 SDA
14 VEE	7 VEE
13 NC	8 TD2+
12 NC	9 TD2-
11 VEE	10 TX2-DIS

Pin Function Definitions

Pin#	Name	Description	Notes
1	VEE	Ground	-
2	NC	No Connection	-
3	NC	No Connection	-
4	VEE	Ground	-
5	SCL	I ² C Clock	-
6	SDA	I ² C Data	-
7	VEE	Ground	-
8	TD2+	Transmit Data In	Note 1
9	TD2-	Inv. Transmit Data In	Note 1
10	TX2-DIS	Transmitter Disable	Note 2, Module disables on high or open
11	VEE	Ground	-
12	NC	No Connection	-
13	NC	No Connection	-
14	VEE	Ground	-
15	VCC	Transmitter Power	Note 3, 3.3V ± 5%
16	VCC	Transmitter Power	Note 3, 3.3V ± 5%
17	VEE	Ground	-
18	TD1+	Transmit Data In	Note 1
19	TD1-	Inv. Transmit Data In	Note 1
20	TX2-DIS	Transmitter Disable	Note 2, Module disables on high or open

Note:

1. TD-/+ : These are the differential transmitter inputs. They are AC-coupled, differential lines with 100 Ω differential termination inside the module.
2. TX-disable is an input that is used to shut down the transmitter optical output. It is pulled up within the module with a 4.7–10 K Ω resistor. Its states are:
 - Low (0 – 0.8V): Transmitter on
 - (>0.8, < 2.0V): Undefined
 - High (2.0 – 3.465V): Transmitter Disabled
 - Open: Transmitter Disabled
3. VCC is the transmitter power supplies. It is defined as 3.3V ±5% at the SFP connector pin. Maximum supply current is 300mA. Recommended host board power supply filtering is shown below. Inductors with DC resistance of less than 1 Ω should be used

in order to maintain the required voltage at the SFP input pin with 3.3V supply voltage. When the recommended supply filtering network is used, hotplugging of the SFP transceiver module will result in an inrush current of no more than 30 mA greater than the steady state value.

Recommended Host Board Supply Filtering

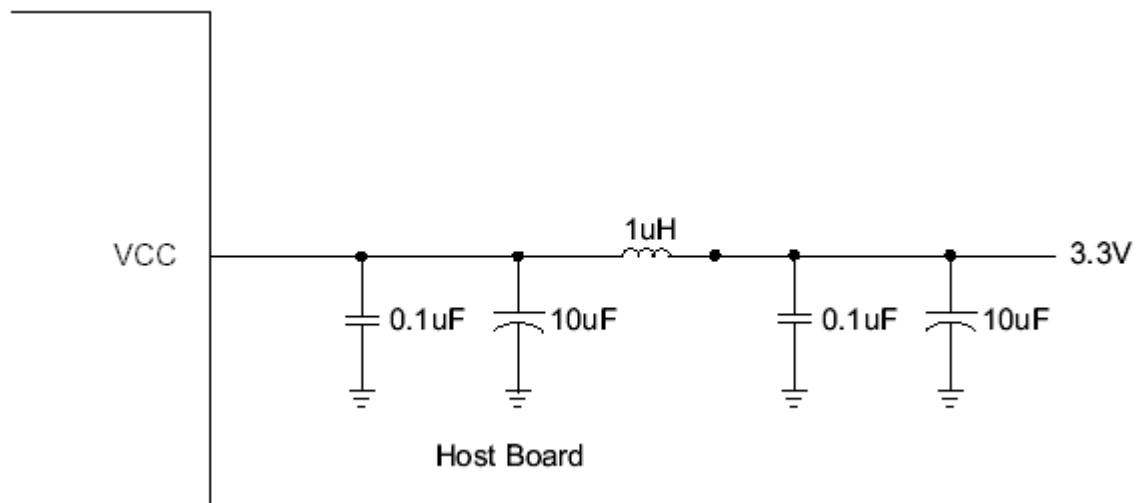

Figure 2: Recommended Host Board Supply Filtering

Optical Connector Requirements

An LC connector with PC/UPC polish is required for each port.

Performance Specifications

Absolute Maximum Ratings

Parameter	Symbol	Min.	Max.	Unit
Storage Temperature	TST	-40	+85	°C
Input Voltage	-	GND	VCC	V
Power Supply Voltage	VCC-VEE	-0.5	+3.6	V

Operating Environment

Parameter	Symbol	Min.	Max.	Unit
Power Supply Voltage	VCC	+3.1	+3.5	V
Operating Temperature	To	0	+70	°C

Transmitter E-O characteristics

Parameter	Symbol	Min.	Typ.	Max.	Unit	Note
Bit Rate	BR	50	-	3000	Mbps	-
Center Wavelength	λ_p	$\lambda-6$	λ	$\lambda+7.5$	nm	T=0~+70°C λ : 1270~1610nm
Spectral Width (RMS)	$\Delta\lambda$	-	-	1	nm	-
Side Mode suppression Ratio	SMSR	30	40	-	dB	-
Average Optical Output Power	Po	-5	-	0	dBm	-
Extinction Ratio	ER	7	-	-	dB	-
Power Supply Current	ICC	-	70	180	mA	-
Transmitter Enable Voltage	VEN	0	-	0.8	-	-
Transmitter disable Voltage	VD	2.0	-	VCC	V	-
Data Inputs Voltage	VPP	300	800	1600	mV	-
Optical Rise Time (20%~80%)	Tr	-	105	165	ps	SMPTE424M 2.97Gbps
		-	170	270	ps	SMPTE 292M 1.485Gbps
		-	300	800	ps	SMPTE 259M 270Mbps
Optical Fall Time (80%~20%)	Tf	-	120	180	Ps	SMPTE 424M 2.97Gbps
		-	170	270	Ps	SMPTE 292M 1.485Gbps
		-	300	800	ps	SMPTE 259M 270Mbps
Optical Signal Intrinsic Jitter	-	-	45	70	ps	SMPTE 424M 2.97Gbps
		-	60	100	ps	SMPTE 292M 1.485Gbps
		-	110	180	ps	SMPTE 259M 270Mbps

Serial Interface

The optical transmitter contains an EEPROM. It provides access to sophisticated identification information that describes the transmitter’s capabilities, standard interfaces, manufacturer, and other information. The serial interface uses the 2-wire serial CMOS EEPROM protocol defined for the ATMEL AT24C01A/02/04 family of components. When the serial protocol is activated, the host generates the serial clock signal (SCL). The positive edge clocks data into those segments of the EEPROM that are not write protected within the transmitter. The negative edge clocks data from the transmitter. The serial data signal (SDA) is bi-directional for serial data transfer. The host uses SDA in conjunction with SCL to mark the start and end of serial protocol activation. The memories are organized as a series of 8-bit data words that can be addressed individually or sequentially.

The Module provides diagnostic information about the present operating conditions. The transmitter generates this diagnostic data by digitization of internal analog signals. Calibration and alarm/warning threshold data is written during device manufacture. Transmitted power monitoring, bias current monitoring, supply voltage monitoring and temperature monitoring all are implemented. The diagnostic data are raw A/D values and must be converted to real world units using calibration constants stored in EEPROM locations 56 – 95 at wire serial bus address A2h. The digital diagnostic memory map specific data field define as following.

Memory Map:

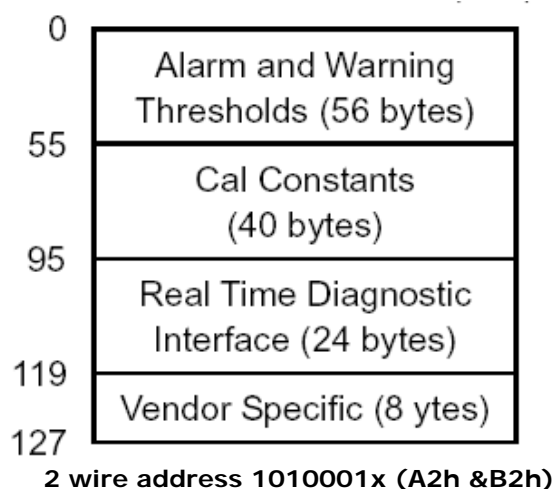
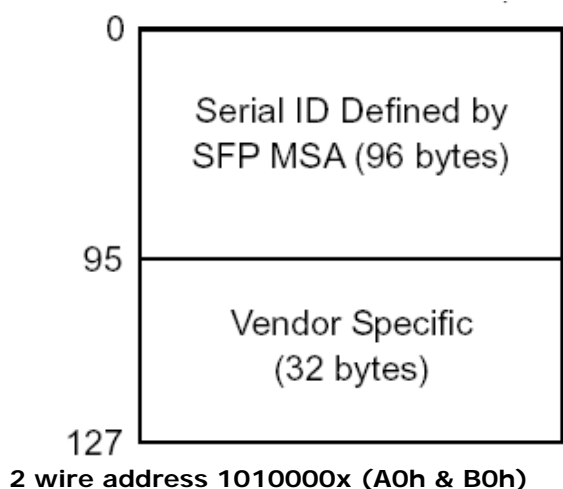

2-wire address A0h & B0h

Addr. (DEC)	Hex value	ASCII	Description	Addr. (DEC)	Hex value	ASCII	Description
0	81		Dual transmitter Video SFP	56	41		Vendor revision
1	04		SFP function is defined by serial ID only	57	31		
2	07		LC Connector	58	20		
3	41		SFP MSA does not specify SMPTE compliance codes	59	20		Wavelength
4	00			60	XX		
5	00			61	XX		
6	00			62	00		Reserved
7	00			63	XX		CC_BASE
8	00			64	00		Options
9	00			65	02		
10	00			66	00		BR, Maximum
11	03		NRZ	67	00		BR, Minimum
12	1E		BR in 100Mbps	68	XX		Vendor serial number
13	00		Reserved	69	XX		
14	02		Length(9u)*km	70	XX		
15	14		Length(9u)100m	71	XX		
16	00		Length(50u)10m	72	XX		
17	00		Length(62.5u)	73	XX		
18	00		Length(Copper)	74	XX		
19	00		Reserved	75	XX		
20	54	T	Vendor name: TRANSWAN	76	XX		
21	52	R		77	XX		
22	41	A		78	XX		
23	4E	N		79	XX		
24	53	S		80	XX		
25	57	W		81	XX		
26	41	A		82	XX		
27	4E	N		83	XX		
28	20			84	XX		
29	20			85	XX		
30	20		86	XX		Vendor date code	
31	20		87	XX			
32	20		88	XX			
33	20		89	XX			
34	20		90	XX			
35	20		91	XX			

36	00		Reserved	92	68		Diag. Monitoring type
37	00		Vendor OUI	93	90		Enhanced options
38	00			94	01		SFF-8472 compliance
39	00			95	XX		CC_EXT
40	32	2	Vendor part number	96-123			2TPXXYYD6-11-SDI
41	54	T		123-127			A1
42	50	P		128-255			Reserved
43	XX	X					
44	XX	X					
45	XX	Y					
46	XX	Y					
47	44	D					
48	36	6					
49	2D	-					
50	31	1					
51	31	1					
52	2D	-					
53	53	S					
54	44	D					
55	49	I					

Note: "XX" denotes hex value which varies from module to module.

2-wire address A2h & B2h

Addr	Size	Name	Description
00-01	2	Temp High Alarm	MSB at low address, +70°C
02-03	2	Temp Low Alarm	MSB at low address, 0°C
04-05	2	Temp High Warning	MSB at low address, +65°C
06-07	2	Temp Low Warning	MSB at low address, +5°C
08-09	2	Voltage High Alarm	MSB at low address, 3.5V
10-11	2	Voltage Low Alarm	MSB at low address, 3.1V
12-13	2	Voltage High Warning	MSB at low address, 3.45V
14-15	2	Voltage Low Warning	MSB at low address, 3.15V
16-17	2	Bias High Alarm	MSB at low address, 70mA
18-19	2	Bias Low Alarm	MSB at low address, 0mA
20-21	2	Bias High Warning	MSB at low address, 60mA
22-23	2	Bias Low Warning	MSB at low address, 5mA
24-25	2	TX Power High Alarm	MSB at low address, -3dBm
26-27	2	TX Power Low Alarm	MSB at low address, -10dBm
28-29	2	TX Power High Warning	MSB at low address, -4dBm
30-31	2	TX Power Low Warning	MSB at low address, -9dBm
32-39	8	N/A	-
40-94	58	Reserved	Reserved for future monitored quantities
95	1	CC_EXT	

Addr	Bit	Name	Description
96	All	Temperature MSB	Internally measured module temperature.
97	All	Temperature LSB	
98	All	Vcc MSB	Internally measured supply voltage in transceiver.
99	All	Vcc LSB	
100	All	TX Bias MSB	Internally measured TX Bias Current.
101	All	TX Bias LSB	
102	All	TX Power MSB	Measured TX output power.
103	All	TX Power LSB	
104-105	All	N/A	-
106	All	Reserved MSB	Reserved for 1st future definition of digitized analog input
107	All	Reserved LSB	Reserved for 1st future definition of digitized analog input
108	All	Reserved MSB	Reserved for 2nd future definition of digitized analog input
109	All	Reserved LSB	Reserved for 2nd future definition of digitized analog input
110	7	TX Disable State	Digital state of the TX Disable Input Pin.
110	6	Soft TX Disable	Read/write bit that allows software disable of laser.
110	5	Reserved	
110	4	RX Rate Select State	Digital state of the SFP RX Rate Select Input Pin. Not supported.
110	3	Soft RX Rate Select	Read/write bit that allows software RX rate select. Not supported.
110	2	TX Fault	Digital state of the TX Fault Output Pin.

110	1	LOS	Digital state of the LOS Output Pin. Not supported
110	0	Data Ready	Indicates transceiver has achieved power up and data is ready
111	7-0	Reserved	Reserved.
112	7	Temp High Alarm	Set when internal temperature exceeds high alarm level.
112	6	Temp Low Alarm	Set when internal temperature is below low alarm level.
112	5	Vcc High Alarm	Set when internal supply voltage exceeds high alarm level.
112	4	Vcc Low Alarm	Set when internal supply voltage is below low alarm level.
112	3	TX Bias High Alarm	Set when TX Bias current exceeds high alarm level.
112	2	TX Bias Low Alarm	Set when TX Bias current is below low alarm level.
112	1	TX Power High Alarm	Set when TX output power exceeds high alarm level.
112	0	TX Power Low Alarm	Set when TX output power is below low alarm level.
113	7-6	N/A	-
113	5	Reserved Alarm	
113	4	Reserved Alarm	
113	3	Reserved Alarm	
113	2	Reserved Alarm	
113	1	Reserved Alarm	
113	0	Reserved Alarm	
114	All	Reserved	
115	All	Reserved	
116	7	Temp High Warning	Set when internal temperature exceeds high warning level.
116	6	Temp Low Warning	Set when internal temperature is below low warning level.
116	5	Vcc High Warning	Set when internal supply voltage exceeds high warning level.
116	4	Vcc Low Warning	Set when internal supply voltage is below low warning level.
116	3	TX Bias High Warning	Set when TX Bias current exceeds high warning level.
116	2	TX Bias Low Warning	Set when TX Bias current is below low warning level.
116	1	TX Power High Warning	Set when TX output power exceeds high warning level.
116	0	TX Power Low Warning	Set when TX output power is below low warning level.
117	7-6	N/A	-
117	5	Reserved Warning	
117	4	Reserved Warning	
117	3	Reserved Warning	
117	2	Reserved Warning	
117	1	Reserved Warning	
117	0	Reserved Warning	
118	All	Reserved	
119	All	Reserved	
120-127	8	Vendor Specific	00h.
128-255	128		Writable Memory

Typical application Circuit

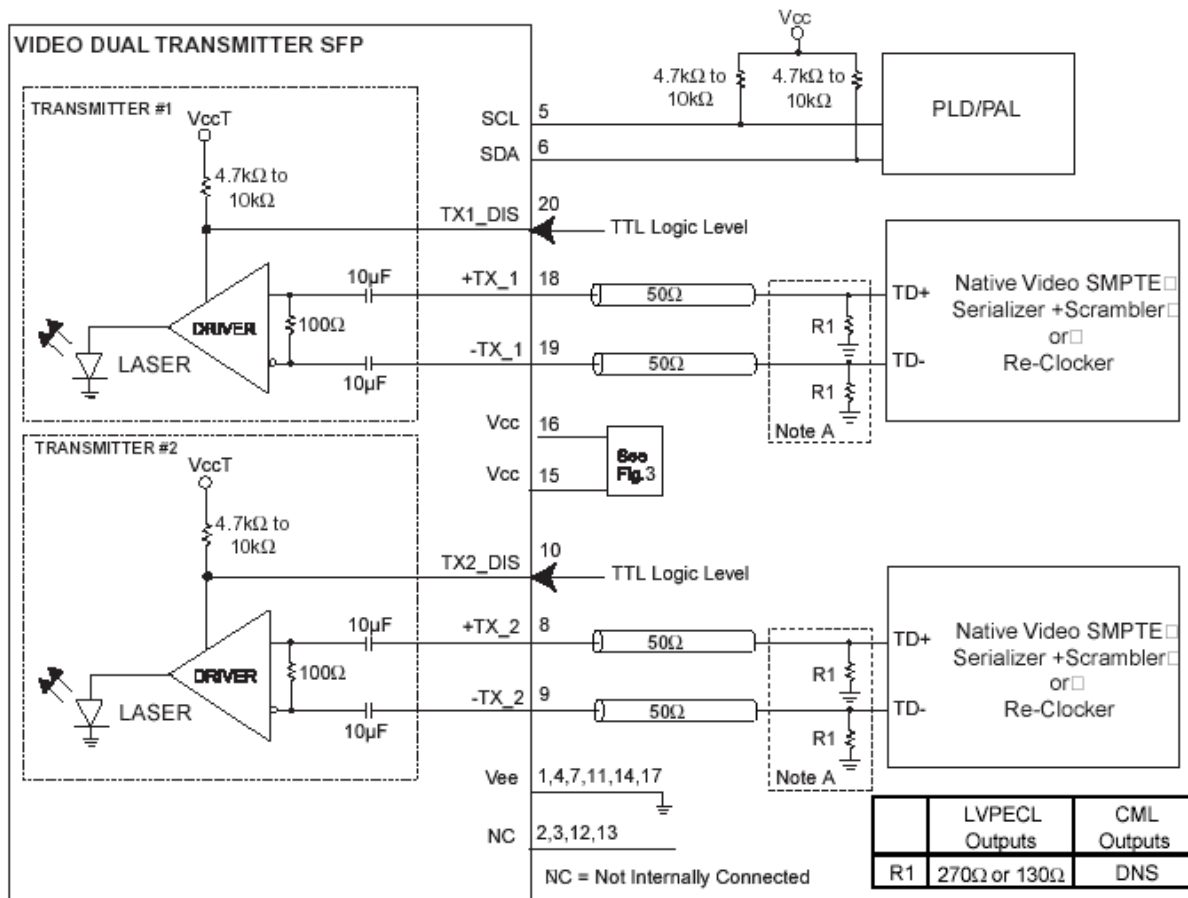
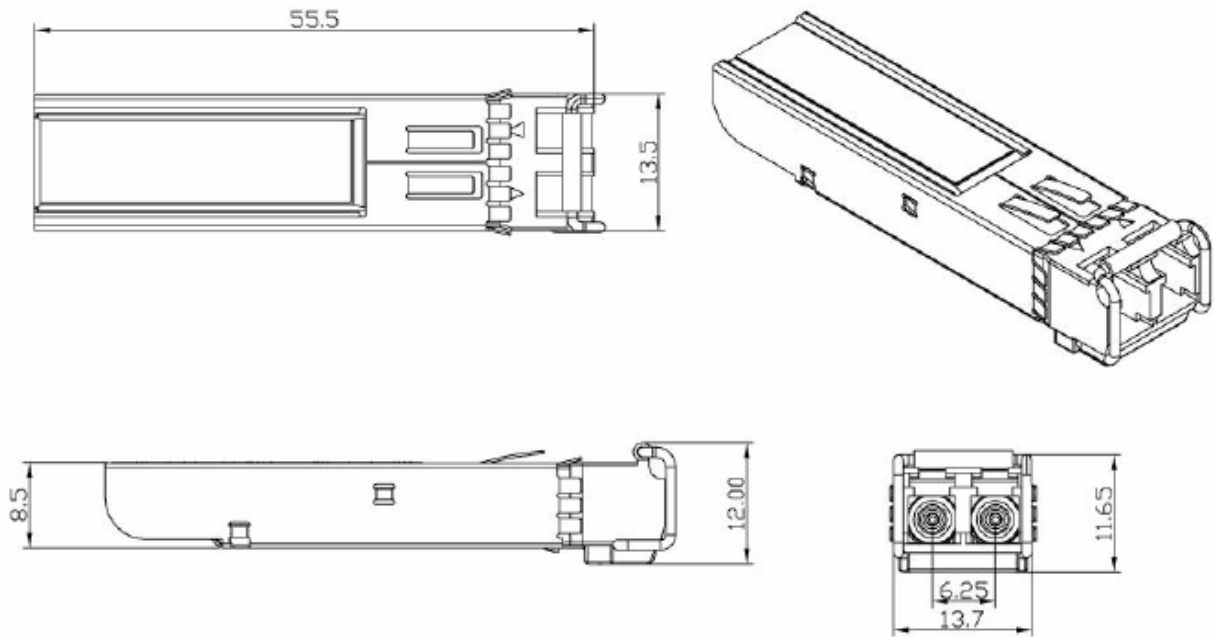

Figure 3: Typical application Circuit

Package information



Unit: mm

For More Information

Shenzhen Transwan Optoelectronic Technology co., Ltd

Add: 5F B Building, Zhi Xuan Han YuanLing Industrial Park, Shi Yan, Bao'an, Shenzhen, P.R.C

Tel: +86-755-29003393, 29003397 Fax: +86-755-29003396, 22630311

E-mail: sales@transwan.com.cn website: www.transwan.com.cn