

## Features

- Transceiver unit with independent
  - 1550nm DFB Laser diode transmitter
  - 1310nm InGaAs PIN photodiode receiver
- Single Fiber Bi-directional Operation ,1×9 pin package and plastic package
- +5V or +3.3V Single power supply, PECL or LVPECL interface logic level
- Integrated WDM Filter, Isolation>35dB and Cross Talk>45dB
- Class I laser product compiles with IEC 60825-1
- Complies with Telcordia GR-468-CORE
- Operating case temperature:
  - Standard : 0 to +70℃
  - Industrial : -40 to +85℃
- Compliant ROHS and lead free

## Application

- SONET/SDH
- ATM
- Ethernet
- CCTV

## Performance Specifications

**Table1. Absolute Maximum Ratings**

Parameter	Symbol	Min	Max	Unit	
Storage Temperature	Tst	-40	+85	℃	
Input Voltage	Vin	GND	Vcc	V	
Power Supply Voltage	Vcc-Vee	CB55D5-1*-13	0	+6.0	V
		CB35D5-1*-13	0	+3.6	
Lead Soldering Temperature/Time	-	-	240/10	℃/S	

**Note: Stress in excess of maximum absolute ratings can cause permanent damage to the module**

**Table2. Operating Environment**

Parameter	Symbol	Min	Max	Unit	
Power Supply Voltage	Vcc	CB55D5-1*-13	+4.75	+5.25	V
		CB35D5-1*-13	+3.1	+3.5	
Ambient Operating Temperature	TA	CB*5D5-11-13	0	+70	℃
		CB*5D5-12-13	-40	+85	

**Table3. Optical and Electrical Characteristics**

(T=25°C, 5V:Vcc=+4.75~+5.25V, 3.3V:Vcc=+3.1~+3.5V Input and output PECL or LVPECL signal)

Parameter	Symbol	Min	Typ	Max	Unit	Note
Transmitter						
Center Wavelength	$\lambda_p$	1520	1550	1580	nm	-
Spectral Width	$\Delta\lambda$ (-20dB)	-	-	1	nm	-
Average Optical Output Power	Po	-10	-	-3	dBm	-
Extinction Ratio	Er	8.2	-	-	dB	-
Optical Rise/Fall Time (20%~80%)	Tr/Tf	-	-	0.26	ns	-
Side Mode Suppression Ratio	SMSR	30	-	-	dB	-
Operating Current	Icc	-	70	180	mA	1
Output Eye	Compliant with IEEE802.3Z					
Data Inputs	PECL/LVPECL					
Receiver						
Parameter	Symbol	Min	Typ	Max	Unit	Note
Center Wavelength	$\lambda_p$	1260	-	1360	nm	-
Sensitivity	Pr	-	-	-23	dBm	2
Maximum Input Power	Ps	-3	-	-	dBm	2
Optical Isolation	Iso	35	-	-	dB	-
Signal Detect Assert Level	Pa(SD H-L)	-35	-	-	dBm	Low-level: Alarm
Signal Detect Deassert Level	Pd(SD L-H)	-	-	-23	dBm	
Signal Detect Hysteresis	-	-	3	-	dB	-
Operating Current	Icc	-	80	100	mA	1
Data Outputs	PECL/LVPECL					
Alarm Output	PECL/LVPECL					

**PECL or LVPECL Input Pins TD+ and TD-**

Parameter	Symbol	Min	Typ	Max	Unit	Note
Input High Voltage	V <sub>IH</sub>	VCC - 1165	-	VCC - 880	mV	3
Input Low Voltage	V <sub>IL</sub>	VCC - 1810	-	VCC - 1475	mV	3

**PECL or LVPECL Output Pins SD, RD+ and RD-**

Parameter	Symbol	Min	Typ	Max	Unit	Note
Low-level Output Voltage	V <sub>OL</sub>	VCC - 1840	-	VCC - 1600	mV	3
High-level Output Voltage	V <sub>OH</sub>	VCC - 1100	-	VCC - 900	mV	3

**Note:**

1. The current excludes the output load current.
2. Minimum Sensitivity and saturation levels for a 2<sup>7</sup>-1 PRBS test pattern@1.25Gb/s
3. RL=50R connected to a level of Vcc -2V.

**Pin Definitions****Pin Out Diagram**

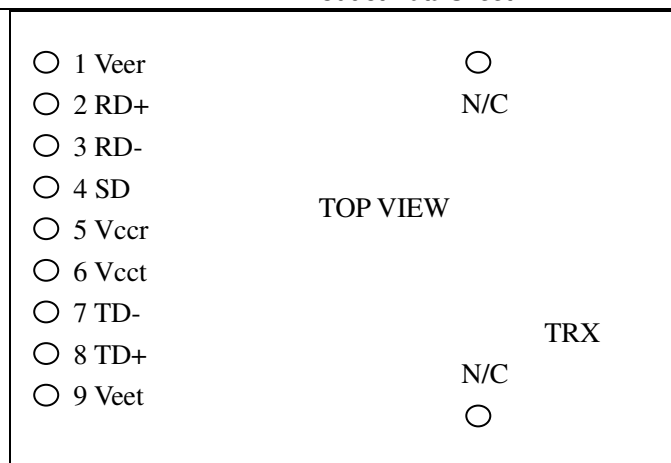

**Pin Description**

Pin#	Pin Name		Logic Level	Description
N/C	Mounting Studs			The two pins are not connected to the transceiver internal circuit.
1	VEER	RX Ground	N/C	Directly connect this pin to receiver signal ground plane.
2	RD+	RX Output Data	PECL/LVPECL	
3	RD-	RX Output Invert Data	PECL/LVPECL	
4	SD	RX Signal Detect	PECL/LVPECL	Normal Operation: Logic "1" Out put , represents that optical is present at receiver input. Fault Condition: Logic "0" output
5	VCCR	RX Power Supply	N/C	Provide +5V/+3.3V DC through the recommended power supply filter circuit. Place the filter circuit as close as possible to the VCCR pin.
6	VCCT	TX Power Supply	N/C	Provide +5V/+3.3V DC through the recommended power supply filter circuit. Place the filter circuit as close as possible to the VCCT pin
7	TD-	TX Invert Data Input	PECL/LVPECL	
8	TD+	TX Data Input	PECL/LVPECL	
9	VEET	TX Ground	N/C	Directly connect this pin to transmitter signal ground plane.

**Package Information**

CB\*5D5-1\*-13

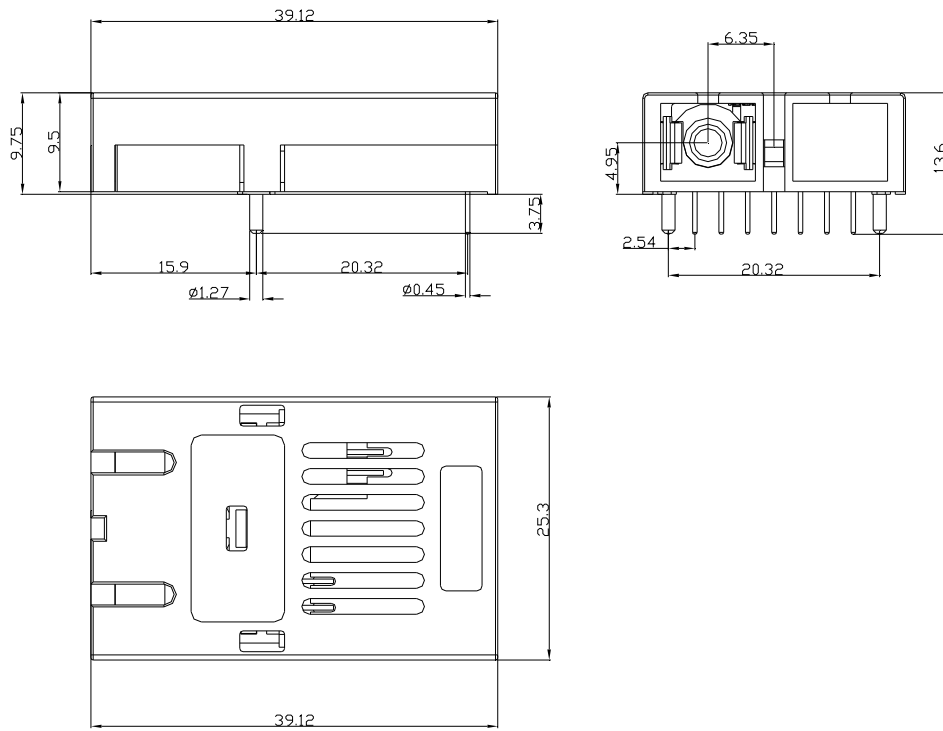

CB\*5D5-1\*-13-T

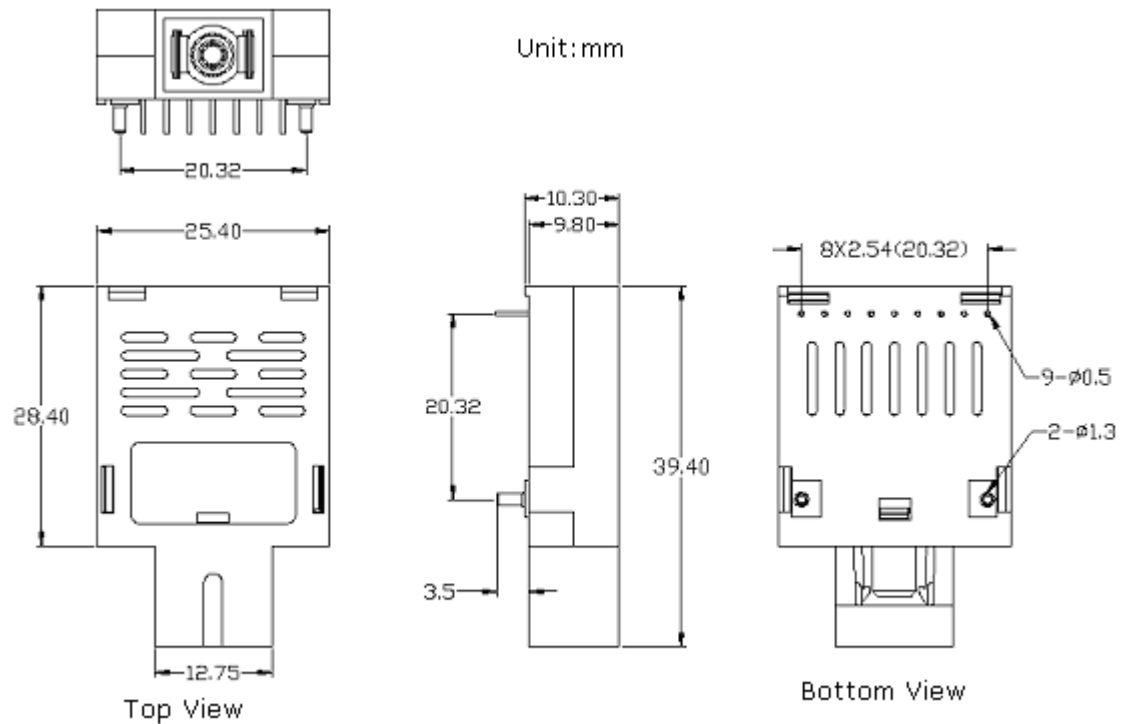

**Recommended Circuit**

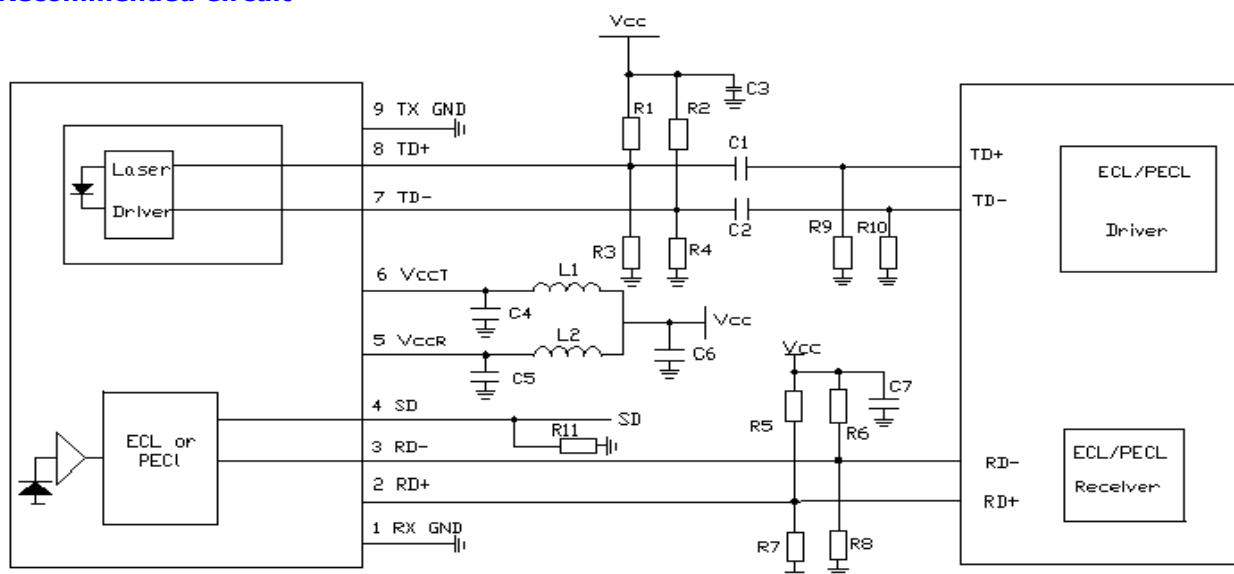

SD: PECL

$C1=C2=C3=C4=C5=C7=0.1\mu F$      $C6=4.7\mu F$      $L1=L2=1\mu H$

$V_{cc}=3.3V$  :  $R1=R2=R5=R6=82\Omega$      $R3=R4=R7=R8=130\Omega$      $R9=R10=R11=180\Omega$

$V_{cc}=5V$  :  $R1=R2=R5=R6=68\Omega$      $R3=R4=R7=R8=180\Omega$      $R9=R10=R11=300\Omega$

**For More Information**

**Shenzhen Transwan Optoelectronic Technology co., Ltd**

**Add: 5F B Building, Zhi Xuan Han YuanLing Industrial Park, Shi Yan, Bao'an, Shenzhen, P.R.C**

**Tel: +86-755-29003393, 29003397 Fax: +86-755-29003396, 22630311**

**E-mail: sales@transwan.com.cn website: www.transwan.com.cn**

**Ordering Information**

