

Features

- Compliant with Fiber Channel 100-M5-SN-I and 100-M6-SN-I standard
- Compliant with IEEE802.3z Gigabit Ethernet standard
- Industry standard small form pluggable (SFP) package
- Duplex LC connector
- Up to 1.25Gbps data links
- 550m transmission distance with 50/125µm or 62.5/125µm MMF
- Differential LVPECL inputs and outputs
- Single power supply +3.3V
- Operating temperature:0 to +70°C
- LVTTTL signal detect indicator
- Hot Pluggable
- Class 1 laser product complies with EN 60825-1
- Compliant ROHS and lead free
- With pull de-latch

Application

- Distributed multi-processing
- Switch to switch interface
- High speed I/O for file server
- Bus extension application
- Channel extender, data storage

Memory Map:

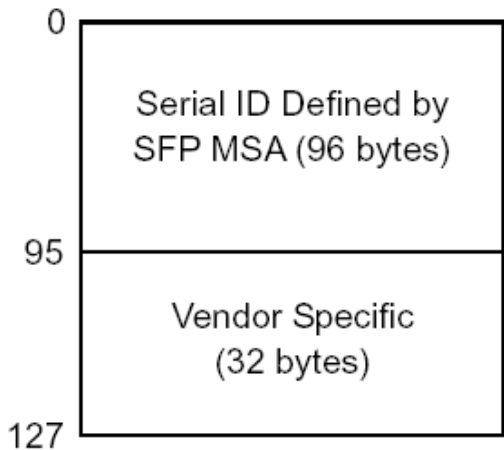

2 wire address 1010000x (A0h)

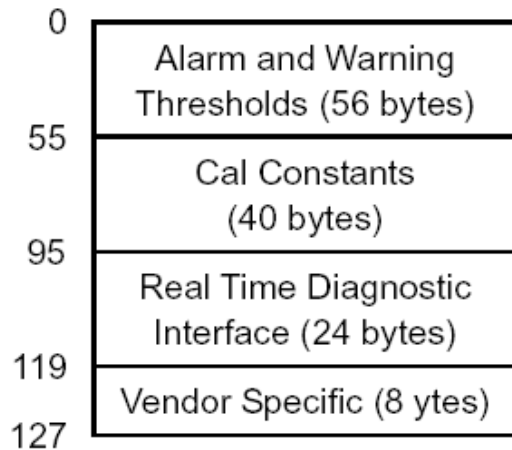

2 wire address 1010001x (A2h)

Block Diagram of Transceiver

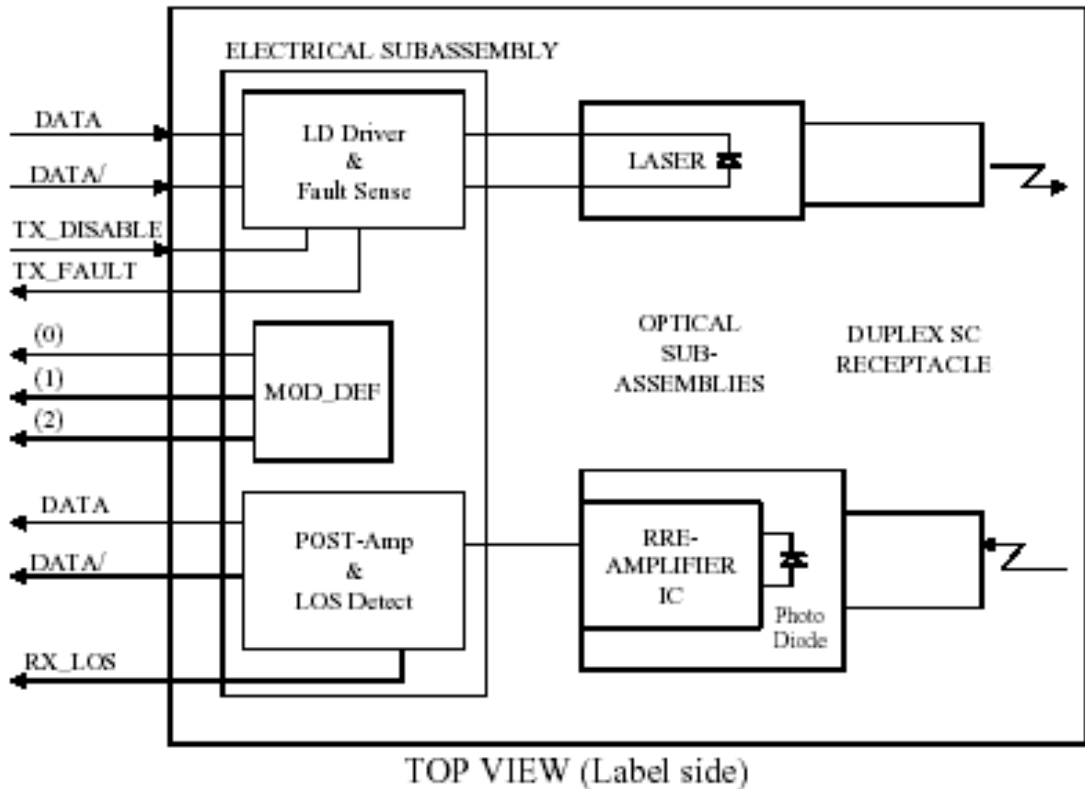

Transmitter Section

The transmitter section consists of a 850 nm VCSEL in an eye safe optical subassembly (OSA) which mates to the fiber cable. The laser OSA is driven by a LD driver IC which converts differential input LVPECL logic signals into an analog laser driving current.

TX_DISABLE

The TX_DISABLE signal is high (TTL logic "1") to turn off the laser output. The laser will turn on when TX_DISABLE is low (TTL logic "0").

Receiver Section

The receiver utilizes a MSM detector integrated with a trans-impedance preamplifier in an OSA. This OSA is connected to a circuit providing post-amplification quantization, and optical signal detection.

Receive Loss (RX_LOS)

The RX_LOS is high (logic "1") when there is no incoming light from the companion transceiver. This signal is normally used by the system for the diagnostic purpose. The signal is operated in TTL level.

Performance Specifications

Table1. Absolute Maximum Ratings

Parameter	Symbol	Min	Max	Unit
Storage Temperature	Tst	-40	+85	°C
Operating Temperature	To	0	+70	°C
Input Voltage	-	GND	Vcc	V
Power Supply Voltage	Vcc-Vee	-0.5	+3.6	V

Note: Stress in excess of maximum absolute ratings can cause permanent damage to the module

Table2. Operating Environment

Parameter	Symbol	Min	Max	Unit
Power Supply Voltage	Vcc	+3.1	+3.5	V
Ambient Operating Temperature	TA	0	+70	°C

Table3. Transmitter electrical and optical Characteristics

Parameter	Symbol	Min	Typ	Max	Unit
Center Wavelength	λ_p	830	850	860	nm
Spectral Width (RMS)	$\Delta\lambda$	-	-	0.85	nm
Coupled Power Ratio	CPR	9	-	-	-
Average Optical Output Power	Po	-10	-	-3	dBm
Extinction Ratio	EXT	9	-	-	dB
Rise/Fall Time, (20~80%)	Tr, f	-	-	260	ps
Relative Intensity Noise	RIN	-	-	117	dB/Hz
Total Jitter	TJ	-	-	227	ps
Max. Pout TX DISABLE Asserted	POFF	-	-	-45	dBm
Differential	Input	0.4	-	2.0	V
Output Eye Diagram	Compliant with IEEE802.3z				

Table 4.Receiver optical-electrical characteristics

Parameter	Symbol	Min	Typ	Max	Unit
Operate Wavelength	-	770	-	860	nm
Sensitivity	Pr	-	-	-17	dBm
Saturation	Ps	-1	-	-	dBm
LOS Asserted	-	-35	-	-	dBm
LOS De-Assert	-	-	-	-17	dBm
Optical Return Loss	ORL	12	-	-	dB
Differential Output Voltage	VDIFF	0.5	-	1.2	V
Data Output Rise, Fall Time (20%~80%)	Tr, f	-	-	0.35	ns
Receiver Loss of Signal Output	RX_LOSL	0	-	0.5	V
Receiver Loss of Signal Output	RX_LOSH	2.4	-	VCC	V

Pin Definition

Pin Out Diagram

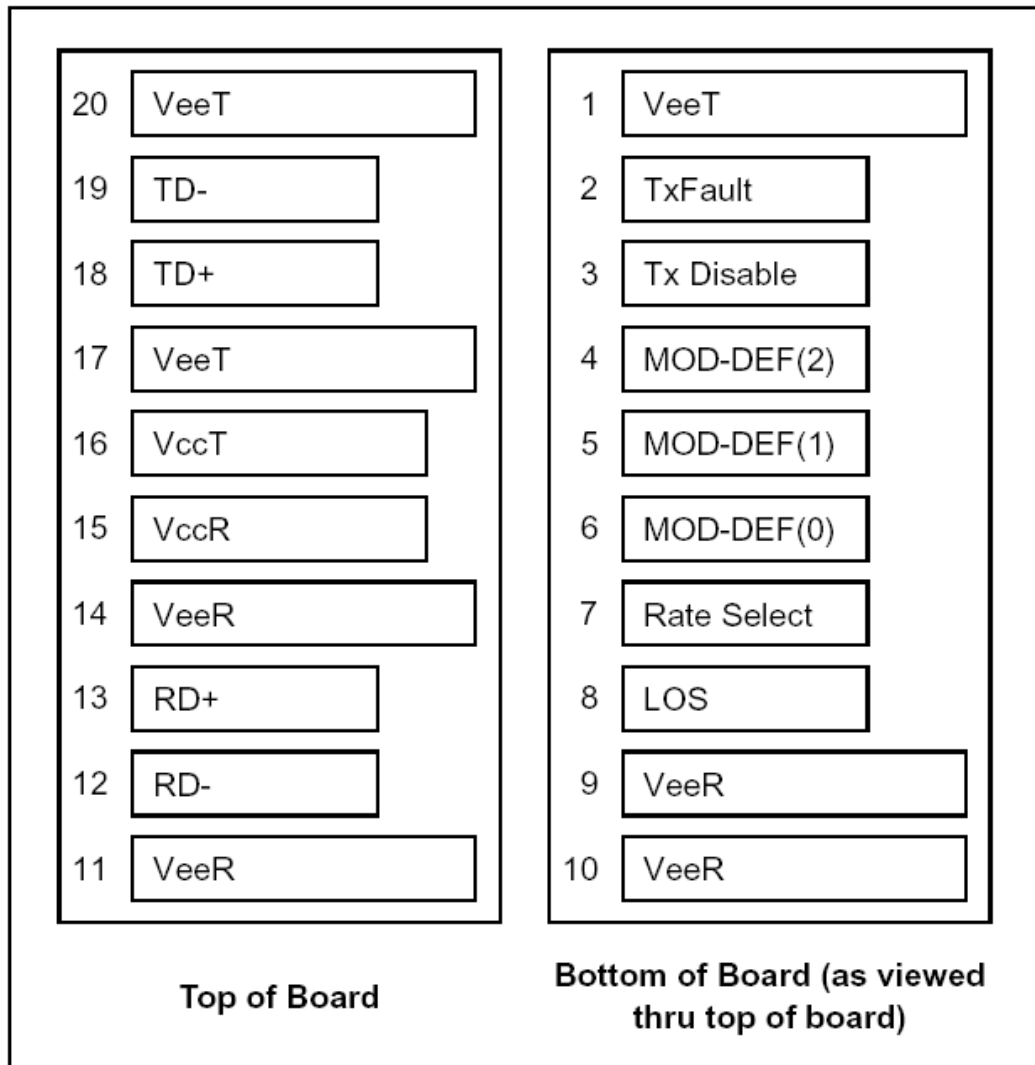
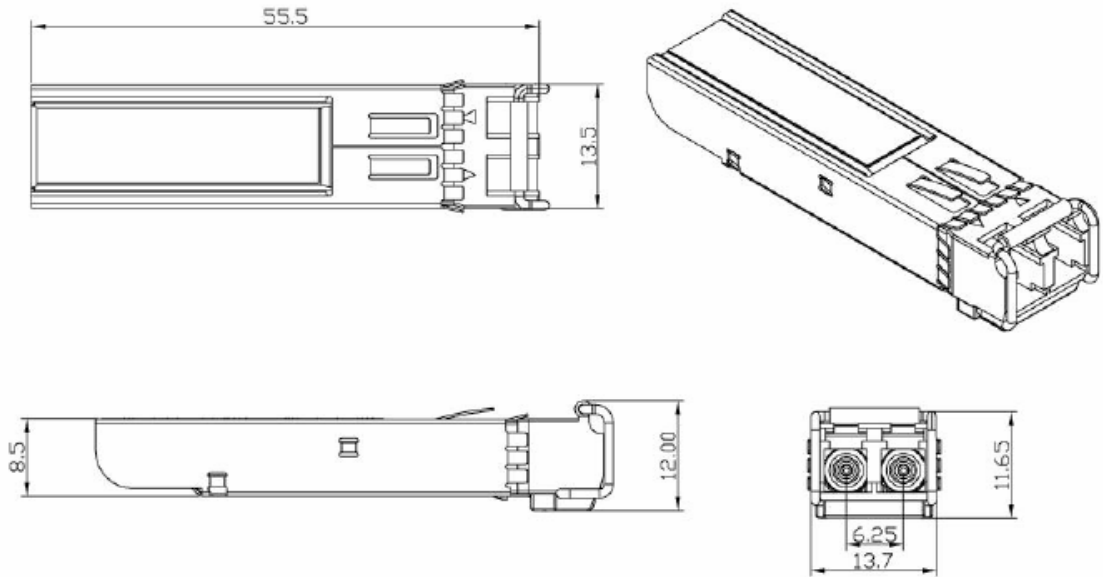

Table5.Pin Function Definitions

Pin#	Name	Description
1	VeeT	Transmitter Ground
2	TX Fault	Transmitter Fault Indication
3	TX Disable	Transmitter Disable
4	MOD-DEF2	Module Definition 2
5	MOD-DEF1	Module Definition 1
6	MOD-DEF0	Module Definition 0
7	Rate Select	Not use
8	LOS	Loss of Signal
9	VeeR	Receiver Ground
10	VeeR	Receiver Ground
11	VeeR	Receiver Ground
12	RD-	Inv. Received Data Out
13	RD+	Receiver Data out
14	VeeR	Receiver Ground
15	VccR	Receiver Power
16	VccT	Transmitter Power
17	VeeT	Transmitter Ground
18	TD+	Transmit Data In
19	TD-	Inv. Transmit Data In
20	VeeT	Transmitter Ground

Package information



Recommended Circuit

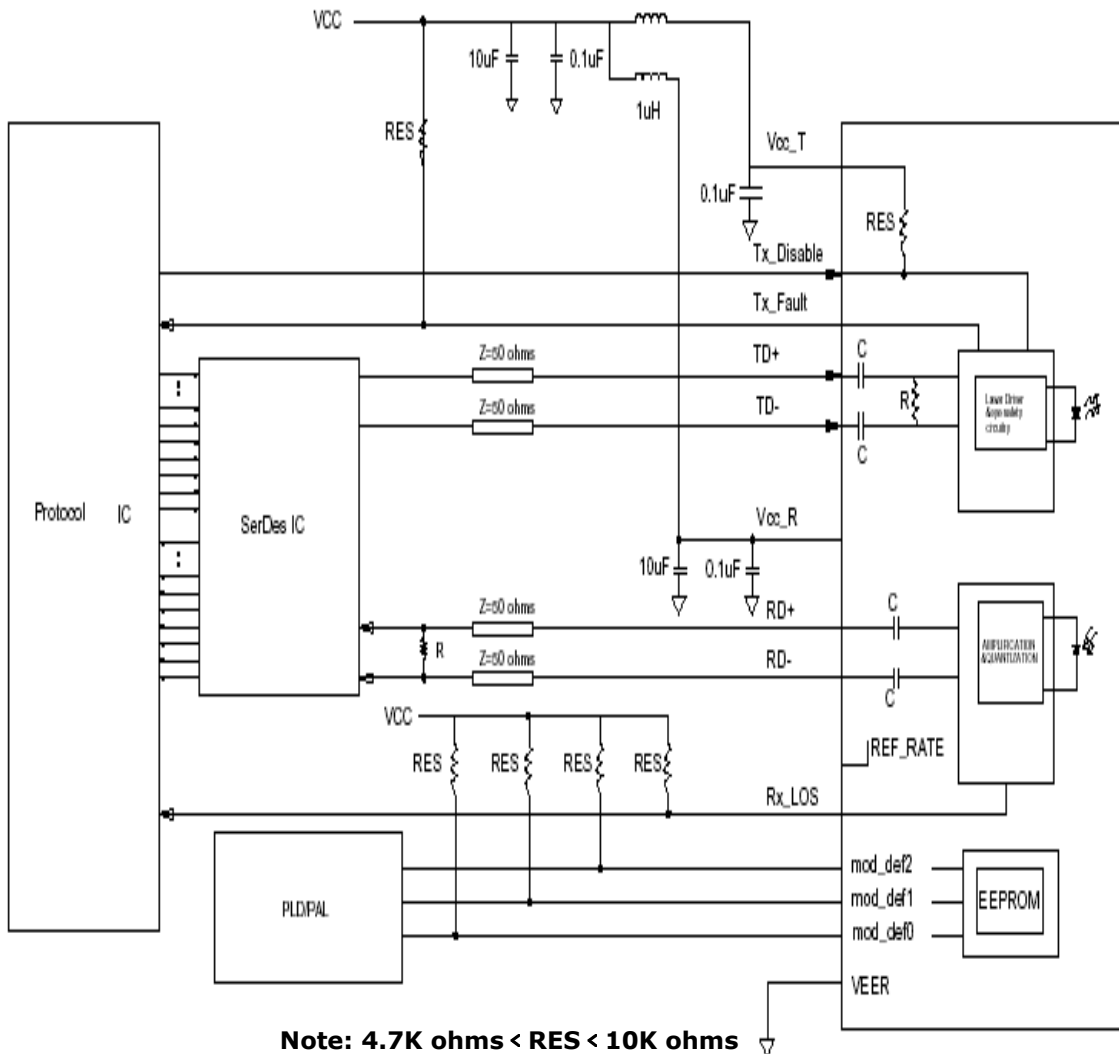

Recommended Board Layout Hole Pattern

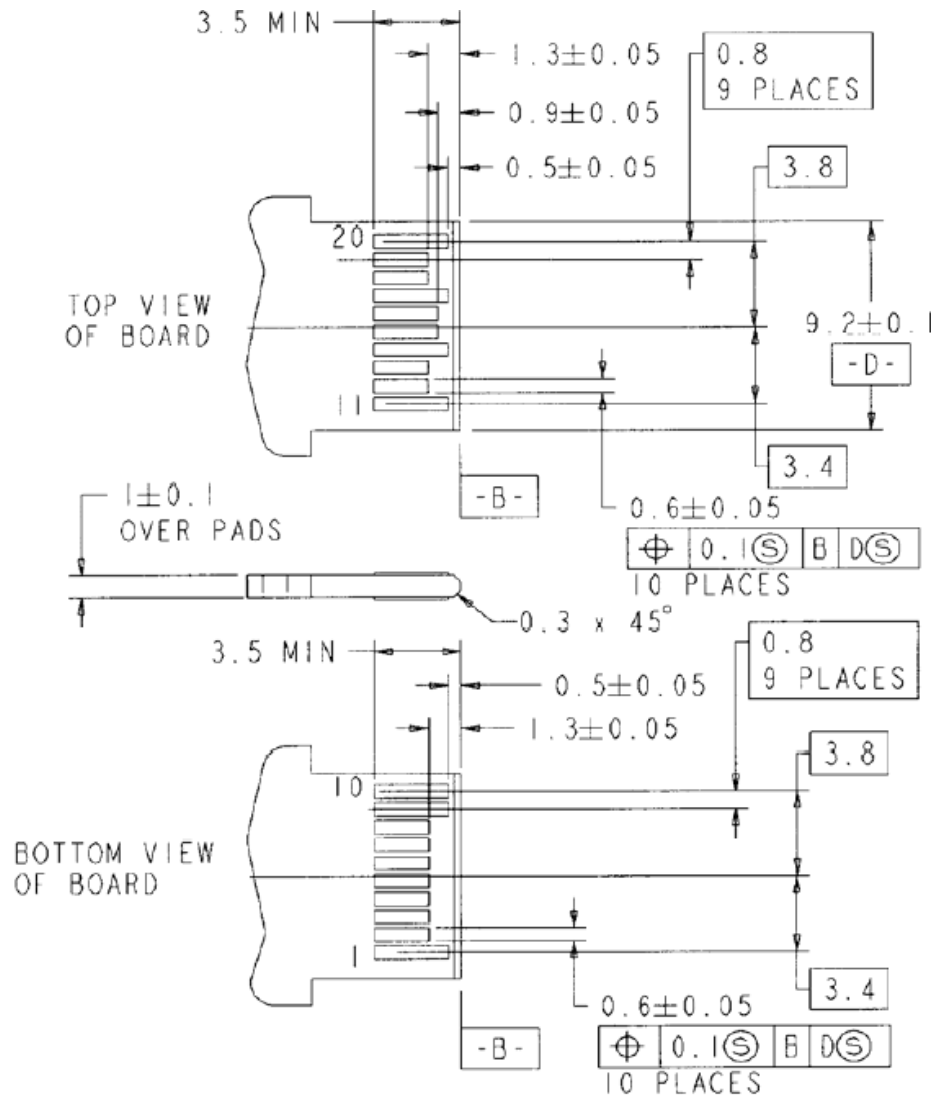

For More Information

Shenzhen Transwan Optoelectronic Technology co., Ltd

Add: 5F B Building, Zhi Xuan Han YuanLing Industrial Park, Shi Yan, Bao'an, Shenzhen, P.R.C

Tel: +86-755-29003393, 29003397 Fax: +86-755-29003396, 22630311

E-mail: sales@transwan.com.cn website: www.transwan.com.cn

Ordering Information

