

Features

- SMPTE 297-2006 compatible
- Robust error free transmission of signals from 50Mbps to 3Gbps
- Maximum distance of 10km under worst-case conditions and 3Gbps video pathological signals
- Supports video pathological patterns for SD-SDI, HD-SDI and 3G-SDI
- SFP Package. Hot-pluggable
- Metal enclosure for lower EMI
- +3.3V single power supply.
- Laser disable pin
- Digital diagnostics and control via I²C interface, including:
 - Monitoring laser bias current, average output power, receive optical power, supply voltage and temperature
 - Alarm reporting when transceiver is at fault
 - Module ID polling
- Compliant ROHS and lead free

Applications

- SMPTE 297-2006 compatible optical-to-electrical interfaces

Descriptions

The CSP15D6-11-SDI is a single channel optical transceiver module designed to transmit and receive optical serial digital signals as defined in SMPTE 297-2006. The CSP15D6-11-SDI is specifically designed for robust performance in the presence of SDI pathological patterns for SMPTE 259M, SMPTE 344M, SMPTE 292M and SMPTE 424M serial rates.

Ordering Information

Part Number	Package	Temperature Range
CSP15D6-11-SDI	SFP	0°C to 70°C

Functional Block Diagram

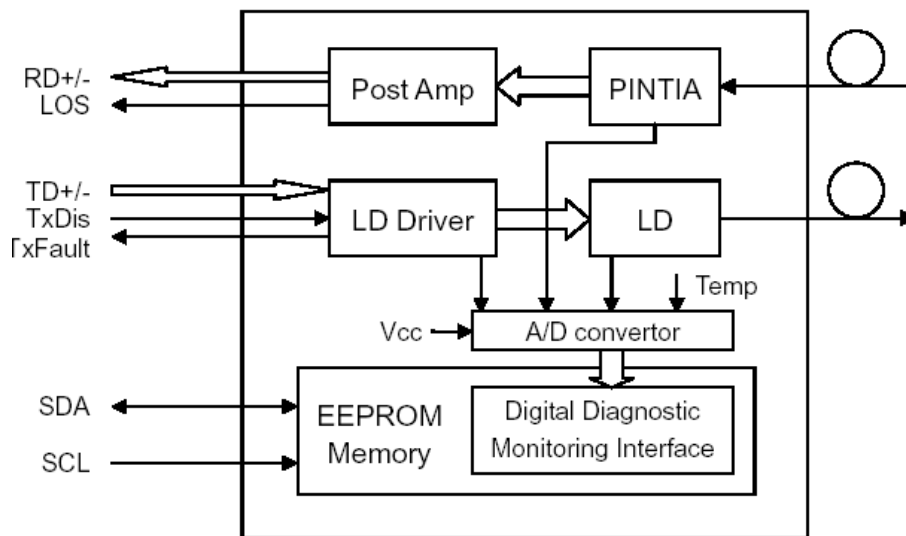

Figure 1: CSP15D6-11-SDI Functional Block Diagram

Pin Description

Pin Out Diagram

20 VEET	1 VEET
19 TD-	2 Tx-Fault
18 TD+	3 Tx-Disable
17 VEET	4 SDA
16 VCCT	5 SCL
15 VCCR	6 Mod-Def
14 VEER	7 NC
13 RD+	8 LOS
12 RD-	9 VEER
11 VEER	10 VEER

Pin Function Definitions

Pin#	Name	Description	Notes
1	VEET	Transmitter Ground	-
2	TX-Fault	Transmitter Fault Indication	Note 1
3	TX-Disable	Transmitter Disable	Note 2, Module disables on high or open
4	SDA	I ² C Data	Note 3
5	SCL	I ² C Clock	Note 3
6	Mod-Def	Module present indicate	Note 3, Grounded in Module
7	NC	No Connection	-
8	LOS	Los of signal	Note 4
9	VEER	Receiver Ground	-
10	VEER	Receiver Ground	-
11	VEER	Receiver Ground	-
12	RD-	Inv. Received Data Out	Note 5
13	RD+	Receiver Data out	Note 5
14	VEER	Receiver Ground	-
15	VCCR	Receiver Power	Note 6, 3.3V \pm 5%
16	VCCT	Transmitter Power	Note 6, 3.3V \pm 5%
17	VEET	Transmitter Ground	-
18	TD+	Transmit Data In	Note 7
19	TD-	Inv. Transmit Data In	Note 7
20	VEET	Transmitter Ground	-

Note:

- TX-Fault is an open collector/drain output, which should be pulled up with a 4.7K–10K Ω resistor on the host board. Pull up voltage between 2.0V and VCC+0.3V. When high, output indicates a laser fault of some kind. Low indicates normal operation. In the low state, the output will be pulled to < 0.8V.
- TX-disable is an input that is used to shut down the transmitter optical output. It is pulled up within the module with a 4.7–10 K Ω resistor. Its states are:
 - Low (0 – 0.8V): Transmitter on
 - (>0.8, < 2.0V): Undefined
 - High (2.0 – 3.465V): Transmitter Disabled
 - Open: Transmitter Disabled
- These pins should be pulled up with a 4.7K – 10K Ω resistor on the host board. The

- pull-up voltage shall be VCCT or VCCR. Mod-Def is grounded by the module to indicate that the module is present .
4. LOS (Loss of Signal) is an open collector/drain output, which should be pulled up with a 4.7K – 10K Ω resistor. Pull up voltage between 2.0V and VccT, R+0.3V. When high, this output indicates the received optical power is below the worst-case receiver sensitivity(as defined by the standard in use). Low indicates normal operation. In the low state, the output will be pulled to < 0.8V.
 5. RD-/+: These are the differential receiver outputs. They are AC coupled 100 Ω differential lines which should be terminated with 100 Ω (differential) at the user SERDES. The AC coupling is done inside the module and is thus not required on the host board.
 6. VccR and VccT are the receiver and transmitter power supplies. They are defined as 3.3V \pm 5% at the SFP connector pin. Maximum supply current is 300mA. Recommended host board power supply filtering is shown below. Inductors with DC resistance of less than 1 Ω should be used in order to maintain the required voltage at the SFP input pin with 3.3V supply voltage. When the recommended supply filtering network is used, hotplugging of the SFP transceiver module will result in an inrush current of no more than 30 mA greater than the steady state value.
 7. TD-/+: These are the differential transmitter inputs. They are AC-coupled, differential lines with 100 Ω differential termination inside the module. The AC coupling is done inside the module and is thus not required on the host board.

Recommended Host Board Supply Filtering

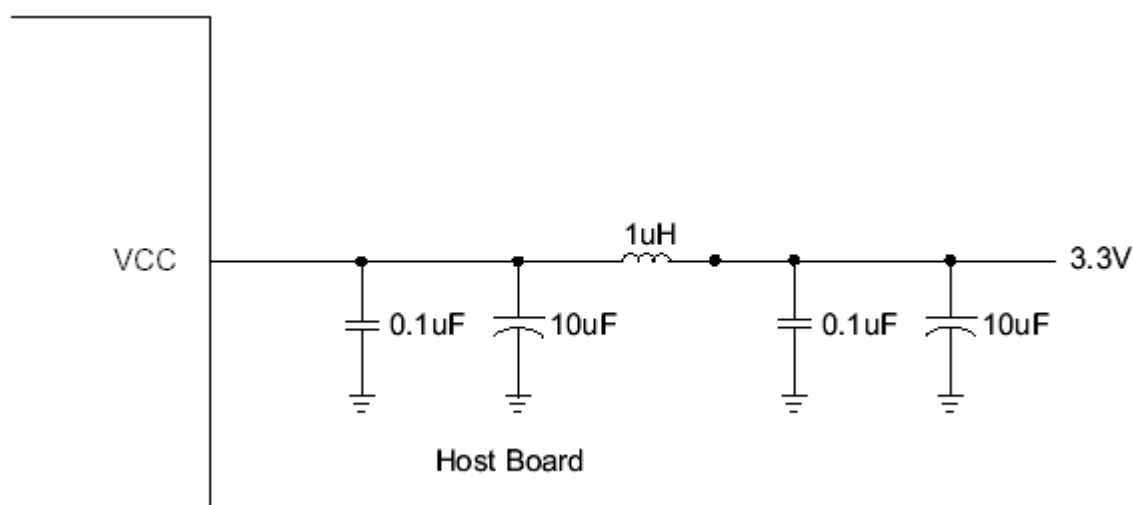

Figure 2: Recommended Host Board Supply Filtering

Optical Connector Requirements

An LC connector with PC/UPC polish is required for each port.

Performance Specifications

Absolute Maximum Ratings

Parameter	Symbol	Min.	Max.	Unit
Storage Temperature	T _{ST}	-40	+85	°C
Operating case Temperature	T _{case}	-20	+85	°C
Input Voltage	-	GND	VCC	V
Power Supply Voltage	VCC-VEE	-0.5	+3.6	V

Operating Environment

Parameter	Symbol	Min.	Max.	Unit
Power Supply Voltage	VCC	+3.1	+3.5	V
Operating Temperature	T _o	0	+70	°C

Transmitter E-O characteristics

Parameter	Symbol	Min.	Typ.	Max.	Unit	Note
Bit Rate	BR	50	-	3000	Mbps	-
Center Wavelength	λ	1520	1550	1580	nm	-
Spectral Width (RMS)	$\Delta\lambda$	-	-	1	nm	-
Average Optical Output Power	P _o	-10	-6	0	dBm	-
Extinction Ratio	ER	5	-	-	dB	-
Power Supply Current	ICC	-	70	180	mA	-
Transmitter Enable Voltage	V _{en}	0	-	0.8	-	-
Transmitter disable Voltage	V _D	2.0	-	VCC	V	-
Data Inputs Voltage	V _{PP}	300	800	1600	mV	-
Optical Rise Time (20%~80%)	Tr	-	105	165	ps	SMPTE 424M 2.97Gbps
		-	170	270	ps	SMPTE 292M 1.485Gbps
		-	300	800	ps	SMPTE 259M 270Mbps

Optical Fall Time (80%~20%)	Tf	-	120	180	ps	SMPTE 424M 2.97Gbps
		-	170	270	Ps	SMPTE 292M 1.485Gbps
		-	300	800	ps	SMPTE 259M 270Mbps
Optical Signal Intrinsic Jitter	-	-	45	70	ps	SMPTE 424M 2.97Gbps
		-	60	100	ps	SMPTE 292M 1.485Gbps
		-	110	180	ps	SMPTE 259M 270Mbps

Receiver O-E characteristics

Parameter	Symbol	Min.	Typ.	Max.	Unit	Note
Bit Rate	BR	50	-	3000	Mbps	-
Wavelength	λ	1260	-	1620	nm	-
Saturation	Ps	-6	-	-	dBm	-
LOS Asserted	-	-35	-	-	dBm	-
LOS De-Assert	-	-	-	-20	dBm	-
LOS Hysteresis	-	-	3	-	dB	-
LOS LOW voltage	VLout	-	-	0.8	V	-
LOS HIGH voltage	VHout	2.0	-	-	V	-
Sensitivity for SMPTE 259M 270Mbps	-	-	-22	-20	dBm	Pathological PRBS
		-	-24	-22	dBm	
Sensitivity for SMPTE 292M 1.485Gbps	-	-	-22	-20	dBm	Pathological PRBS
		-	-24	-22	dBm	
Sensitivity for SMPTE 424M 2.97Gbps	-	-	-19	-18	dBm	Pathological PRBS
		-	-21	-20	dBm	
Data Outputs Voltage	Vpp	400	800	1000	mV	-
Input Power Monitoring Accuracy		-1		+1	dB	-

Note: The sensitivity specification refers to the input power levels for BER = 1E-12 against PRBS 2²³-1.

EEPROM Section

The optical transceiver contains an EEPROM. It provides access to sophisticated identification information that describes the transceiver’s capabilities, standard interfaces, manufacturer, and other information. The serial interface uses the 2-wire serial CMOS EEPROM protocol defined for the ATMEL AT24C01A/02/04 family of components. When the serial protocol is activated, the host generates the serial clock signal (SCL). The positive edge clocks data into those segments of the EEPROM that are not write protected within the SFP transceiver. The negative edge clocks data from the SFP transceiver. The serial data signal (SDA) is bi-directional for serial data transfer. The host uses SDA in conjunction with SCL to mark the start and end of serial protocol activation. The memories are organized as a series of 8-bit data words that can be addressed individually or sequentially.

The Module provides diagnostic information about the present operating conditions. The transceiver generates this diagnostic data by digitization of internal analog signals. Calibration and alarm/warning threshold data is written during device manufacture. Received power monitoring, transmitted power monitoring, bias current monitoring, supply voltage monitoring and temperature monitoring all are implemented. The diagnostic data are raw A/D values and must be converted to real world units using calibration constants stored in EEPROM locations 56 – 95 at wire serial bus address A2h. The digital diagnostic memory map specific data field define as following.

Memory Map:

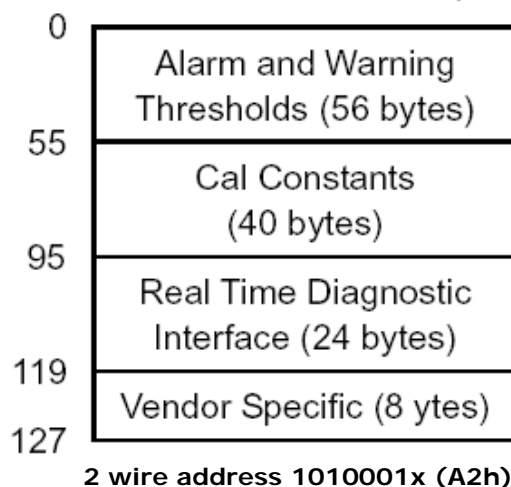
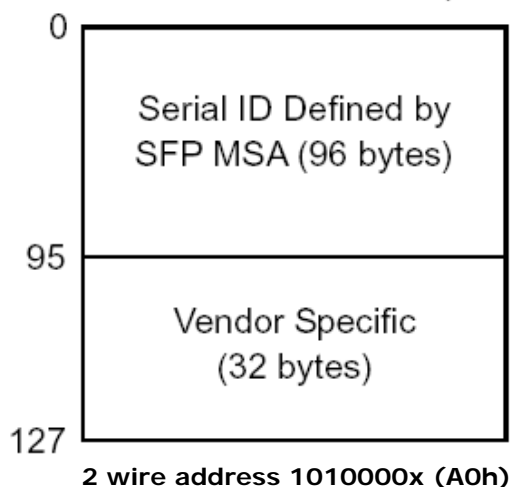

Recommended Circuit

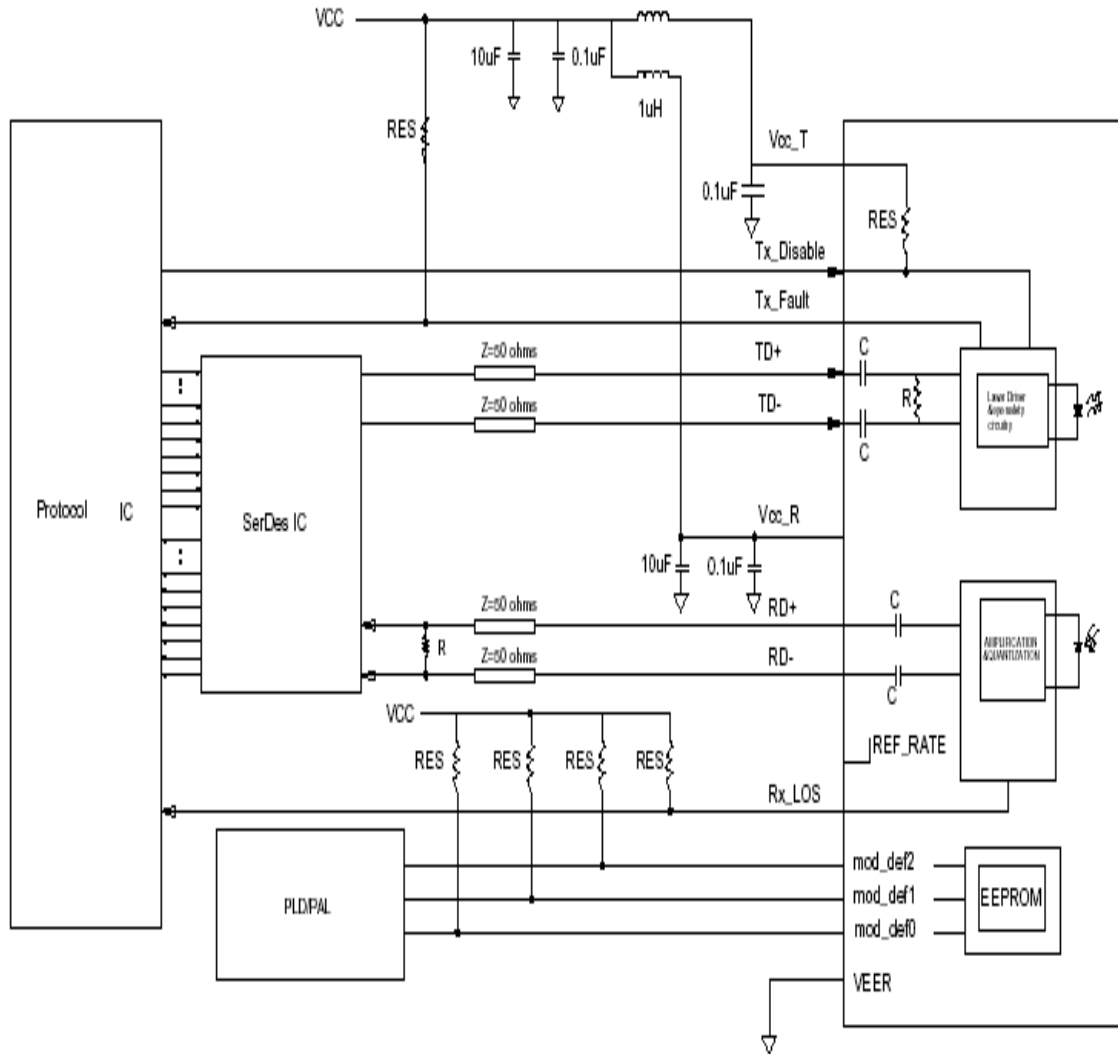

Note: $4.7K\ \text{ohms} < RES < 10K\ \text{ohms}$

Figure 3: Recommended Circuit

Package information

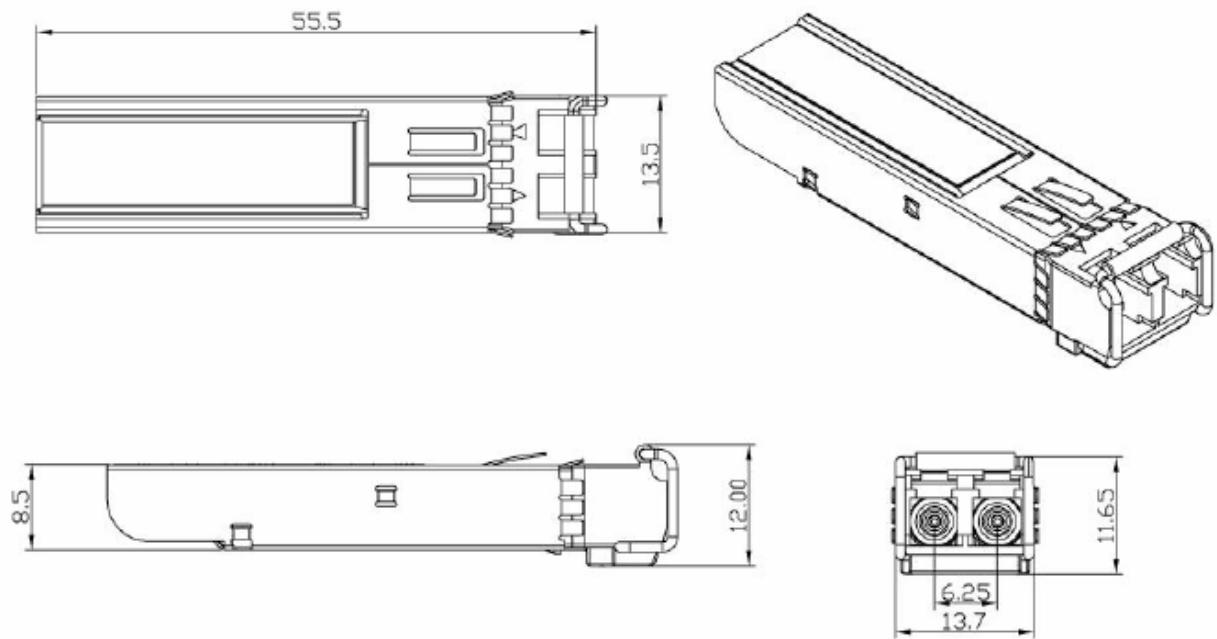

Unit: mm

For More Information

Shenzhen Transwan Optoelectronic Technology co., Ltd

Add: 5F B Building, Zhi Xuan Han YuanLing Industrial Park, Shi Yan, Bao'an, Shenzhen, P.R.C

Tel: +86-755-29003393, 29003397 Fax: +86-755-29003396, 22630311

E-mail: sales@transwan.com.cn website: www.transwan.com.cn